

LOC		DIST		REVISIONS			
DF	DO	P	LTR	DESCRIPTION	DATE	DWN	APVD
		P		REVISED PER ECO-09-012539	20-03-09	CT	RL

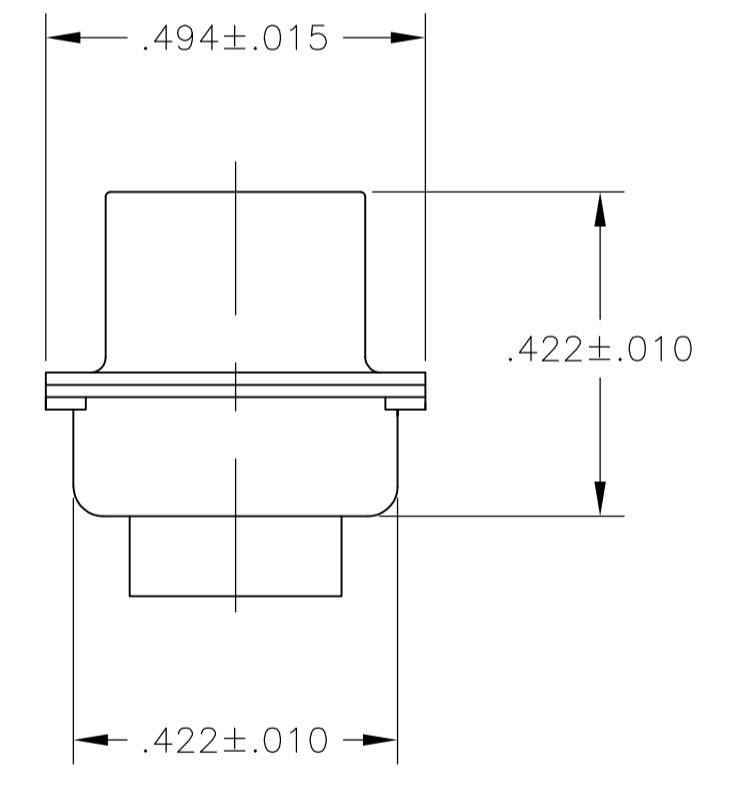
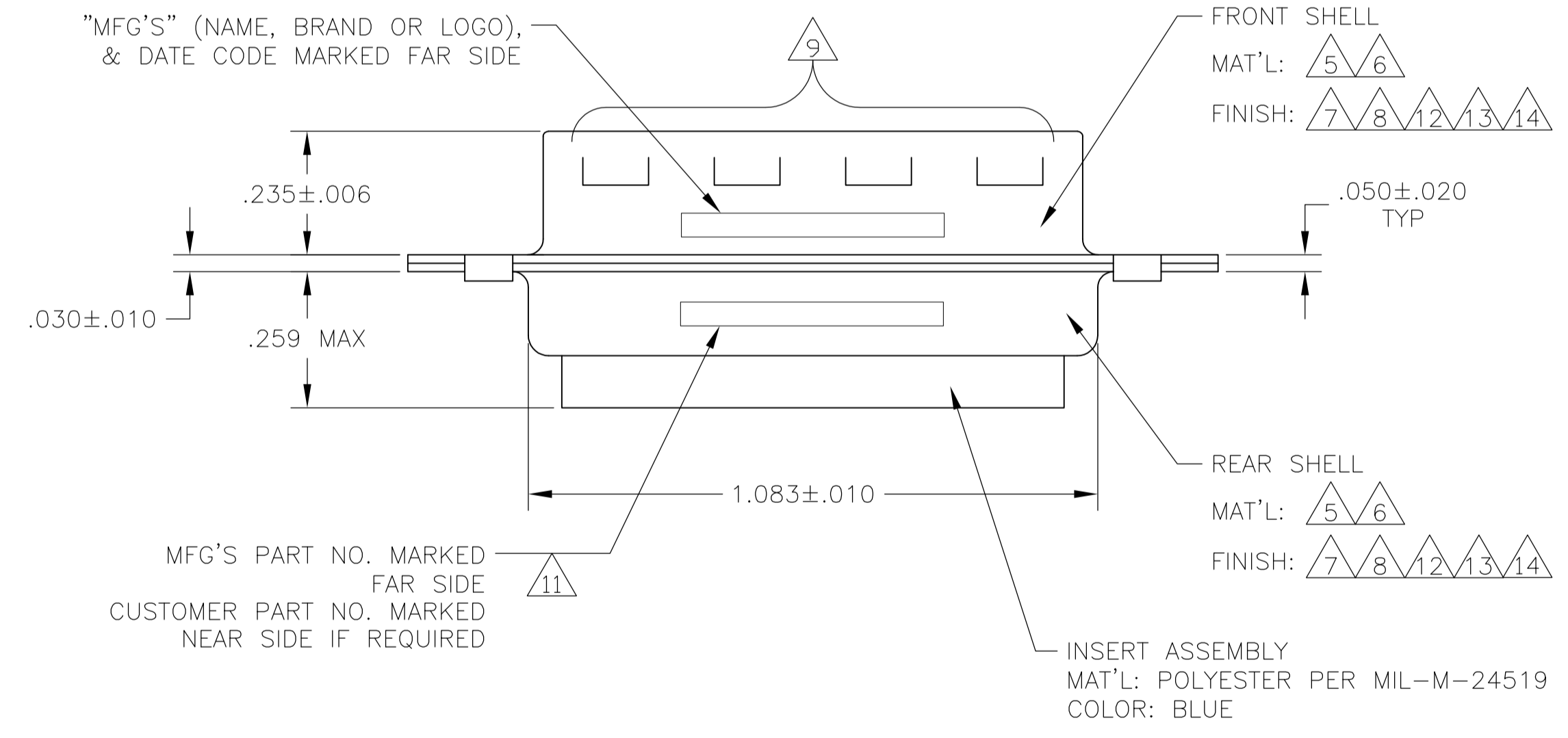
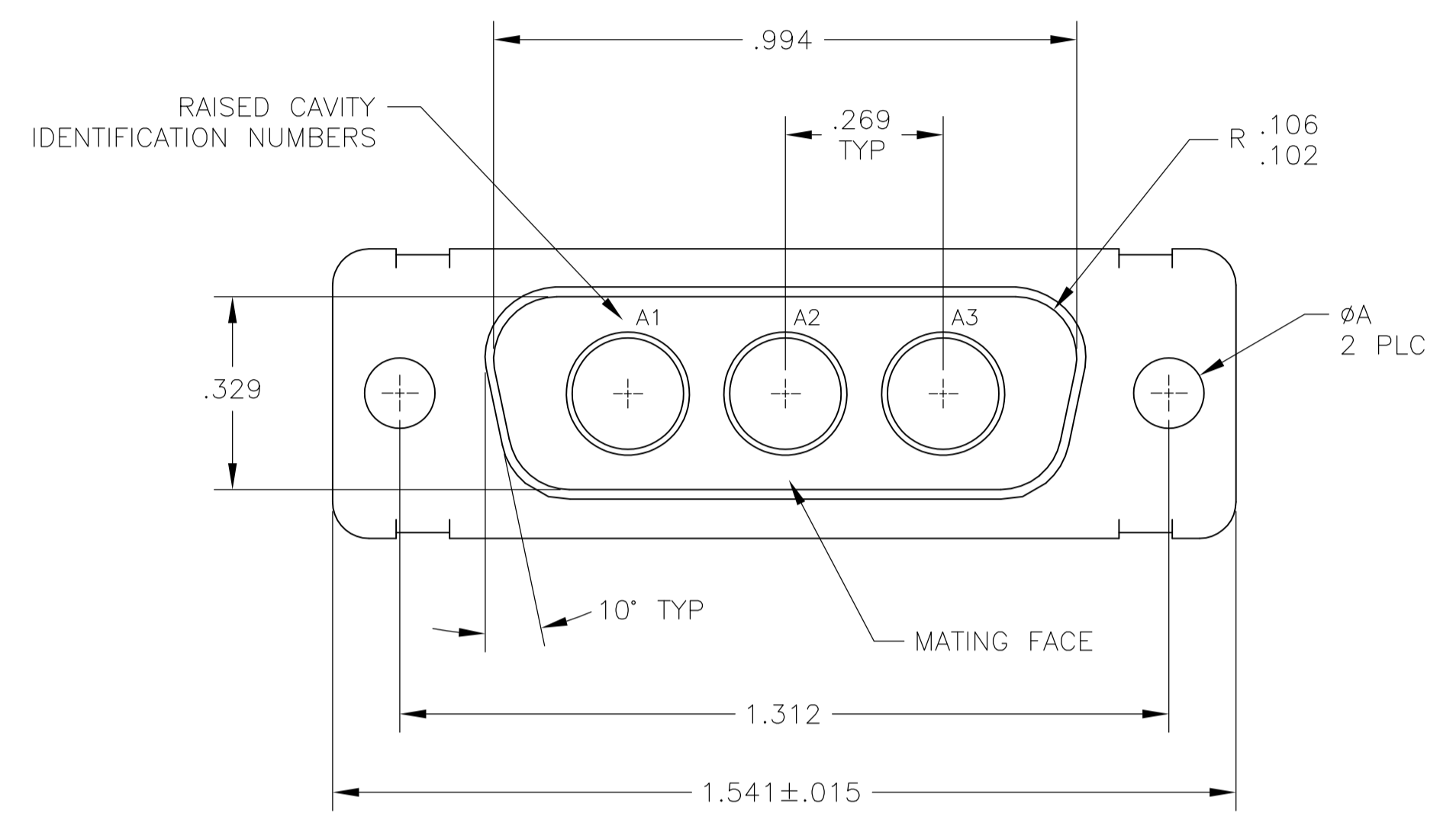

- THIS PLUG WILL MATE WITH ANY 3C3, SIZE 2 RECEPTACLE IN AMPLIMITE SERIES.
- THIS PLUG IS DESIGNED TO CONFORM TO THE LATEST ISSUE OF MIL-C-24308.
- THIS CONNECTOR ACCEPTS (3) POWER 8, OR COAX PIN CONTACTS IN POSITIONS A1 THRU A3, PURCHASED SEPARATELY.
- RAISED NUMBERS FOR IDENTIFICATION OF CIRCUIT HOLES.
- STEEL PER ASTM-A-109.
- BRASS PER MIL-C-50 AND ASTM-B-36 UNS NO. C26000.
- CADMIUM PLATED PER QQ-P-416.
- GOLD PLATED PER MIL-G-45204 TYPE II, GRADE C, CLASS 1 OVER COPPER PER MIL-C-14550, CLASS IV.
- GROUNDING INDENTS FOR 448153-4 & 5-448153-4 ONLY.
- "MFG'S" (NAME, BRAND OR LOGO) AND DATE CODE INK STAMPED ON FRONT SHELL, FAR SIDE. MFG'S PART NUMBER INK STAMPED ON REAR SHELL, FAR SIDE. FAR SIDE REFERS TO WIDE SIDE OF KEYSTONE.
- CUSTOMER PART NUMBER MAY BE SPLIT BETWEEN FRONT AND REAR SHELL, NEAR SIDE.
- FINISH: TIN PER ASTM-B-545 .000200 MIN THK OVER COPPER PER AMS2418 .000100-.000200 THK.
- FINISH: TIN PER ASTM-B-545 .000200 MIN THK OVER COPPER PER AMS2418 .000100-.000200 THK.
- FINISH: ZINC PLATE PER ASTM-B-633 .000200-.000400 THK WITH SUPPLEMENTARY CHROMATE (Cr3+).

REMARKS	ØA	CUSTOMER PART NO.	PART NO.
5 7	.120 [3.05]	T5935-0103-002	448153-7
13 10 5 9	.120 [3.05]	-	5-448153-4
5 14	.120 [3.05]	-	5-448153-1
6 8	.120 [3.05]	B010942-0013	448153-5
12 10 5 9	.120 [3.05]	-	448153-4
6 8	.154 [3.91]	311P405-7P-B-15	448153-3
6 8	.120 [3.05]	311P405-7P-B-12	448153-2
5 7	.120 [3.05]	-	448153-1

THIS DRAWING IS A CONTROLLED DOCUMENT.

DIMENSIONS: INCHES	TOLERANCES UNLESS OTHERWISE SPECIFIED:	DIN W. LUFERT 06FEB91	APVD W. BERNHART 24MAR92	NAME W. BERNHART 24MAR92	SIZE	CAGE CODE	DRAWING NO	RESTRICTED TO
0 PLC ± -	1 PLC ± -	2 PLC ± -	3 PLC ± .005(0.13)	4 PLC ± -	ANGLES ± 0° 30'	A1	00779	448153
MATERIAL	FINISH	Tyco Electronics Corporation Harrisburg, PA 17105-3608		PRODUCT SPEC	APPLICATION SPEC	WEIGHT	SCALE	SHEET 1 OF 1
		Tyco Electronics		PLUG ASSEMBLY AMPLIMITE 3C3 SIZE 2, SERIES 109, COAX	CUSTOMER DRAWING	SCALE 4:1	SHEET 1 OF 1	REV P