

THIS DRAWING IS UNPUBLISHED. RELEASED FOR PUBLICATION
 © COPYRIGHT - BY TYCO ELECTRONICS CORPORATION. ALL RIGHTS RESERVED.

LOC	DIST	REVISIONS			
P	LTR	DESCRIPTION	DATE	DWN	APVD
	B	REVISED (ECR-08-030901)	24DEC08	FY	WK
	B1	REVISED PER ECO-10-000444	18JAN10	KK	AEG

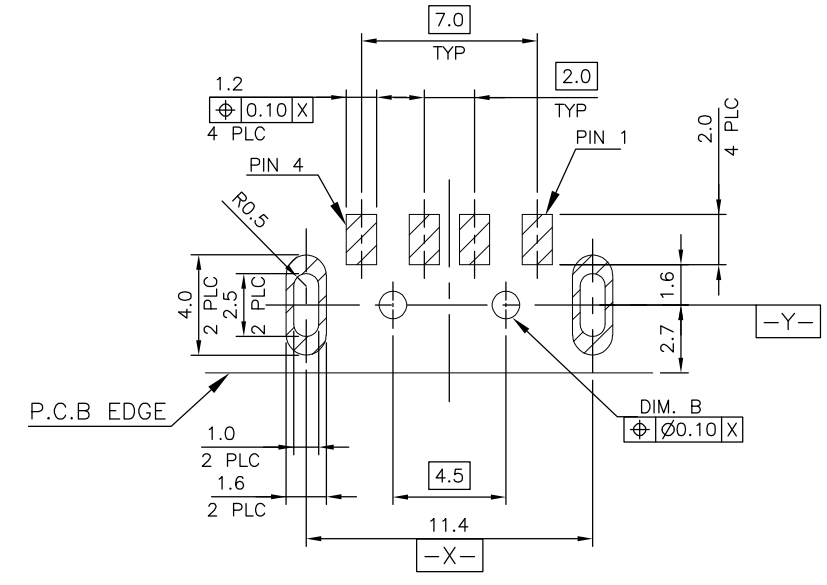

RECOMMENDED PCB LAYOUT (THICKNESS: 1.6mm)
 (COMPONENT VIEW) TOLERANCE: 1PLC:±0.1 2PLC:±0.05

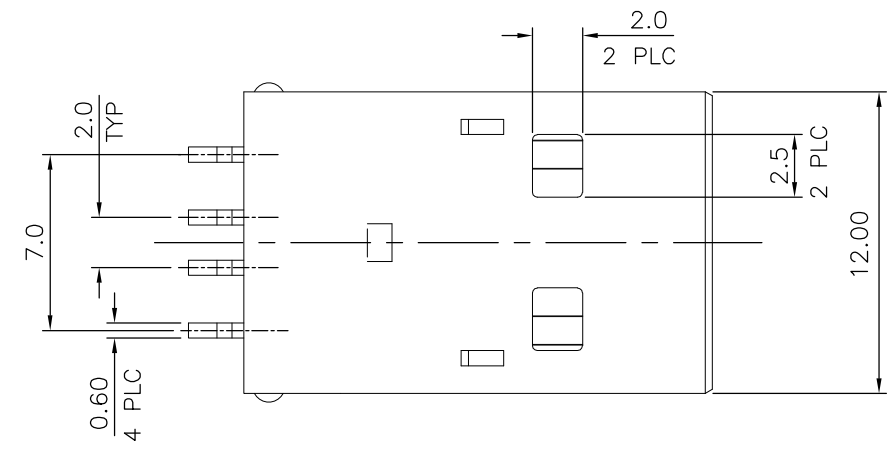
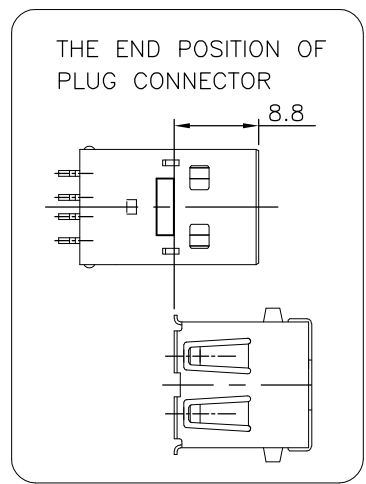
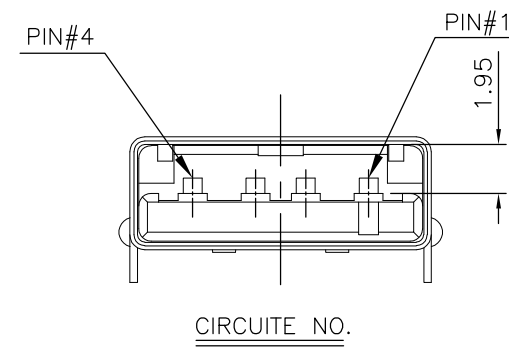
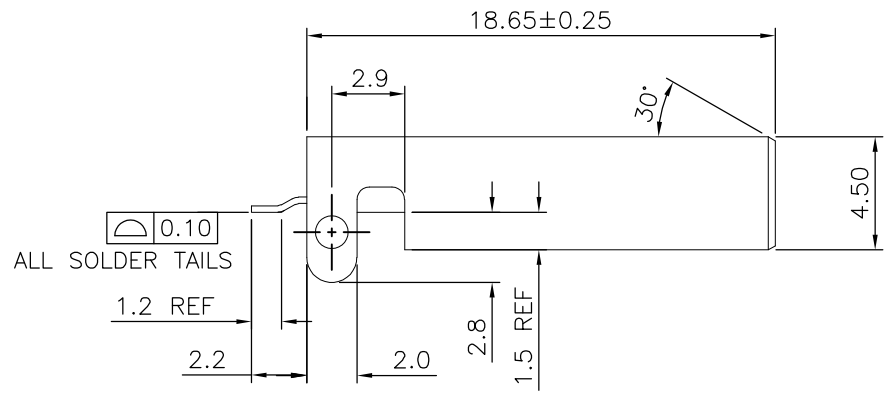
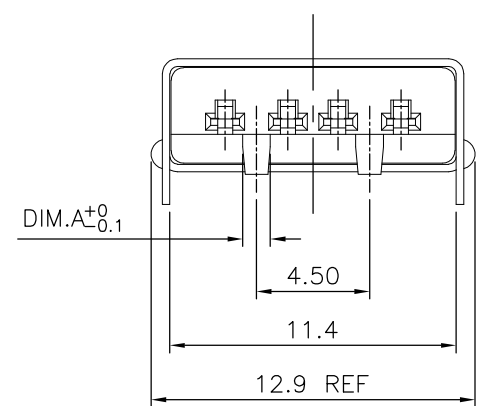

- NOTE:
- MATERIAL:
 HOUSING: PA-6T WITH 30% GF, UL 94V-0 COLOR: SEE TABLE.
 CONTACT: BRASS.
 SHIELD: COLD ROLL STEEL, (SPCC-1).
 - FINISH:
 CONTACTS: 0.76um [30u"] MIN GOLD PLATING ON CONTACT AREA,
 2.54um [100u"] MIN TIN-COPPER ON SOLDER TAILS.
 1.27um [50u"] MIN NICKEL UNDERPLATED ALL OVER.
 SHELL: 3.048um [120u"] MIN NICKEL PLATED OVER
 5.08um [200u"] MIN Cu UNDERPLATED ALL OVER.
 - REFLOW SOLDER CAPABLE TO 260°C PER TE TEST SPEC.
 109-201, CONDITION B.

5 OBSOLETE PARTS: OBSOLETE CIS STREAMLINING PER D.RENAUD/D.SINISI

REEL	Ø1.40	Ø1.50	BLACK	1-1734028-4
		Ø1.00	Ø1.10	BLACK
TRAY	Ø1.40	Ø1.50	NATURE	1-1734028-2
	Ø1.00	Ø1.10	NATURE	1-1734028-1
	Ø1.40	Ø1.50	BLACK	1734028-4
	Ø1.00	Ø1.10	BLACK	1734028-3
	Ø1.40	Ø1.50	NATURE	1734028-2
	Ø1.00	Ø1.10	NATURE	1734028-1

THIS DRAWING IS A CONTROLLED DOCUMENT.		DWN F. YANG 24DEC2008	Tyco Electronics Corporation	
DIMENSIONS: MM		CHK S. CHIEN 24DEC2008	Tyco Electronics Taipei, Taiwan	
TOLERANCES UNLESS OTHERWISE SPECIFIED:		APVD W. KODAMA 24DEC2008	NAME	
0 PLC ± 0.40		PRODUCT SPEC	USB CONNECTOR, PLUG, R/A, SMT TYPE	
1 PLC ± 0.30		108-57306	SIZE	CAGE CODE
2 PLC ± 0.20		QUALIFICATION TEST REPORT	501-57337	DRAWING NO
3 PLC ± 0.10		WEIGHT --	A3	00779
4 PLC ± -		CUSTOMER DRAWING	C=1734028	
ANGLES ± 3.0°		SCALE 1:1	SHEET 1 OF 3	REV B1
FINISH		RESTRICTED TO		
SEE NOTE		SEE NOTE		

4

3

2

1

THIS DRAWING IS UNPUBLISHED. RELEASED FOR PUBLICATION
 © COPYRIGHT BY TYCO ELECTRONICS CORPORATION. ALL RIGHTS RESERVED.

LOC	DIST	REVISIONS			
P	LTR	DESCRIPTION	DATE	DWN	APVD
		SEE SHEET 1.			

D
C
B
A

D
C
B
A

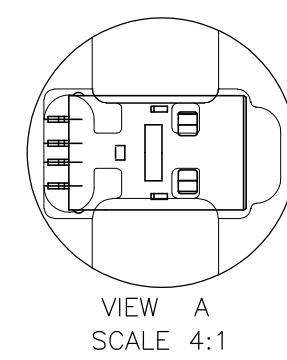
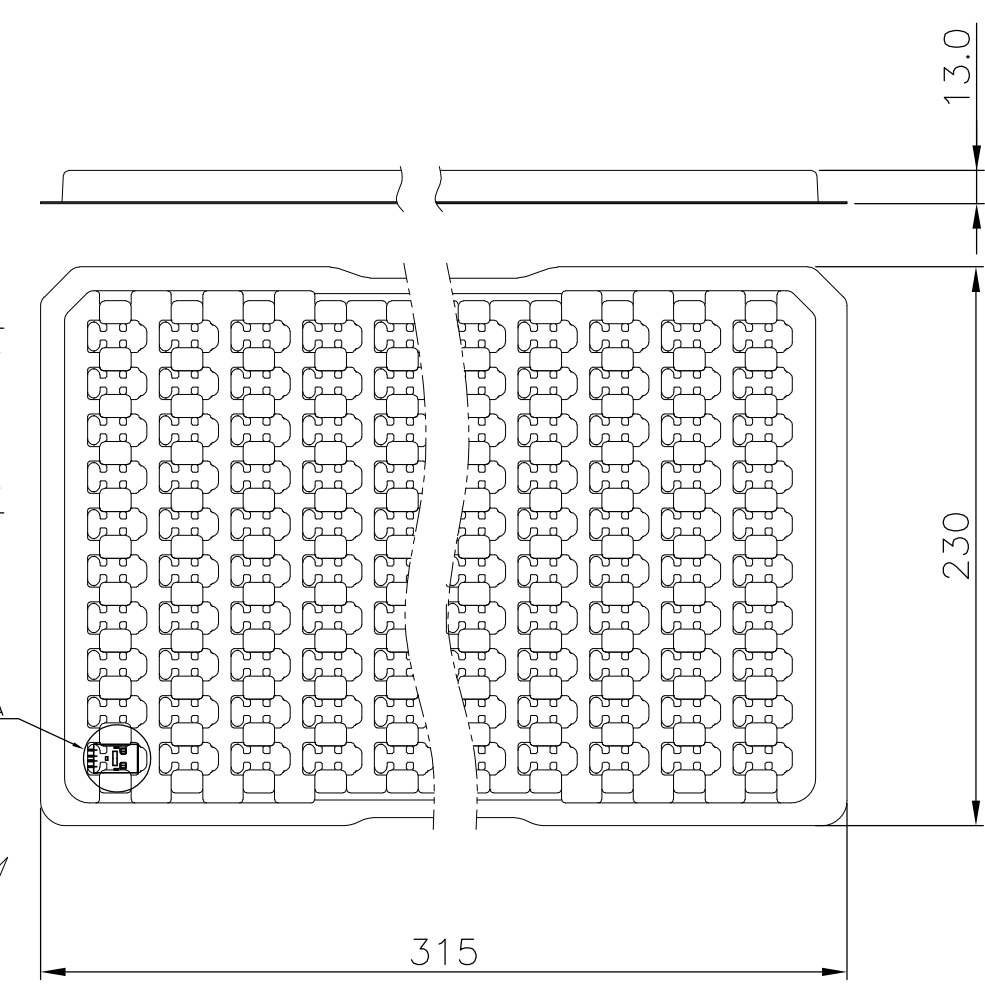
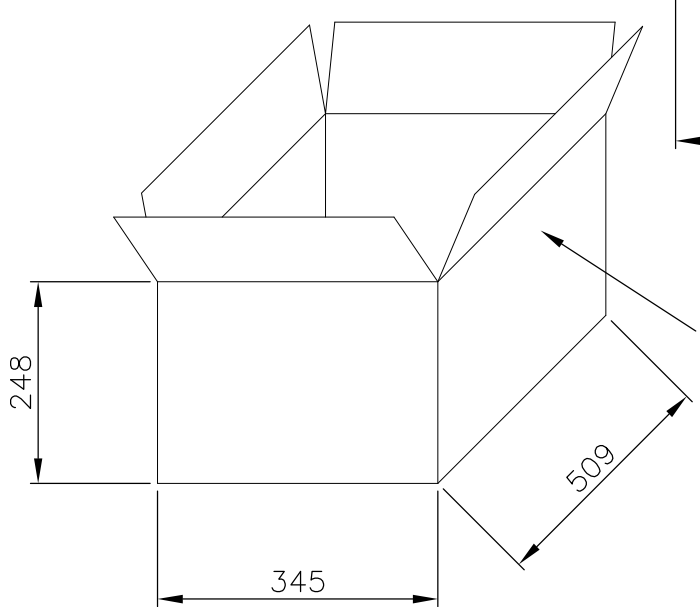
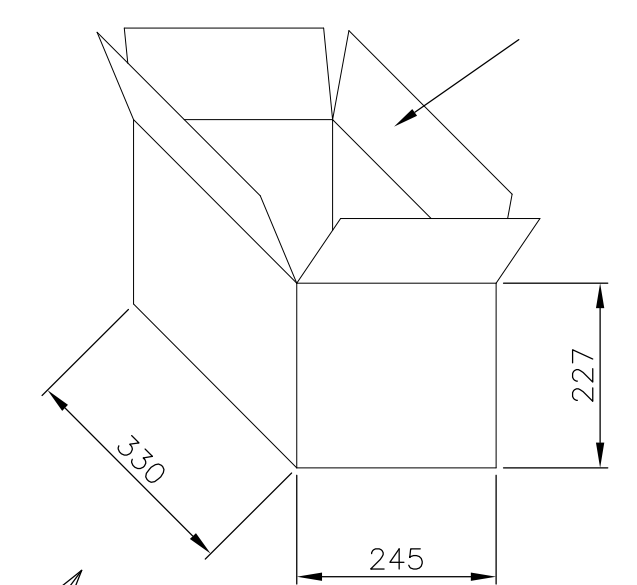
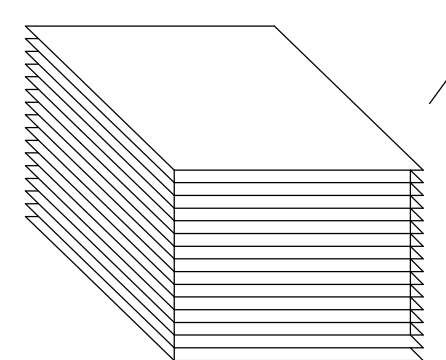
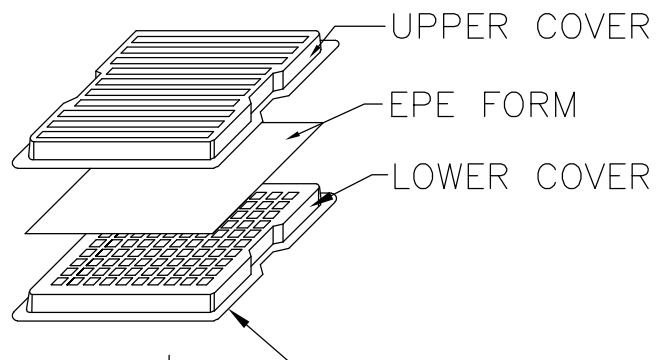
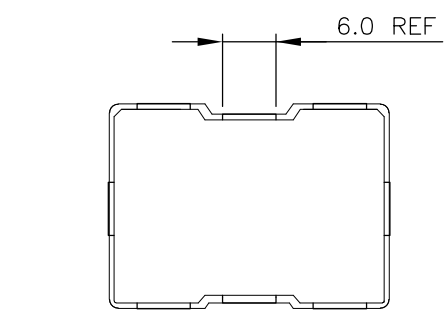

16.5kg	15.5kg	100	32	3200PCS
GROSS WEIGHT	NET WEIGHT	PCS/TRAY	TRAYS / CARTON	QUANTITY

THIS DRAWING IS A CONTROLLED DOCUMENT.		DWN		Tyco Electronics Corporation Taipei, Taiwan	
DIMENSIONS: MM		CHK		NAME	
TOLERANCES UNLESS OTHERWISE SPECIFIED:		APVD		USB CONNECTOR, PLUG, R/A, SMT TYPE	
0 PLC ± -		PRODUCT SPEC		SIZE CAGE CODE DRAWING NO RESTRICTED TO	
1 PLC ± -		APPLICATION SPEC		A3 00779 C=1734028	
2 PLC ± -		WEIGHT		CUSTOMER DRAWING	
3 PLC ± -		SCALE		SHEET 2 OF 3 REV B1	
4 PLC ± -		MATERIAL			
ANGLES ± -		FINISH			

THIS DRAWING IS UNPUBLISHED. RELEASED FOR PUBLICATION
 © COPYRIGHT BY TYCO ELECTRONICS CORPORATION. ALL RIGHTS RESERVED.

LOC DW	DIST /	REVISIONS		
P	LTR	DESCRIPTION	DATE	DWN APVD
		SEE SHEET 1.		

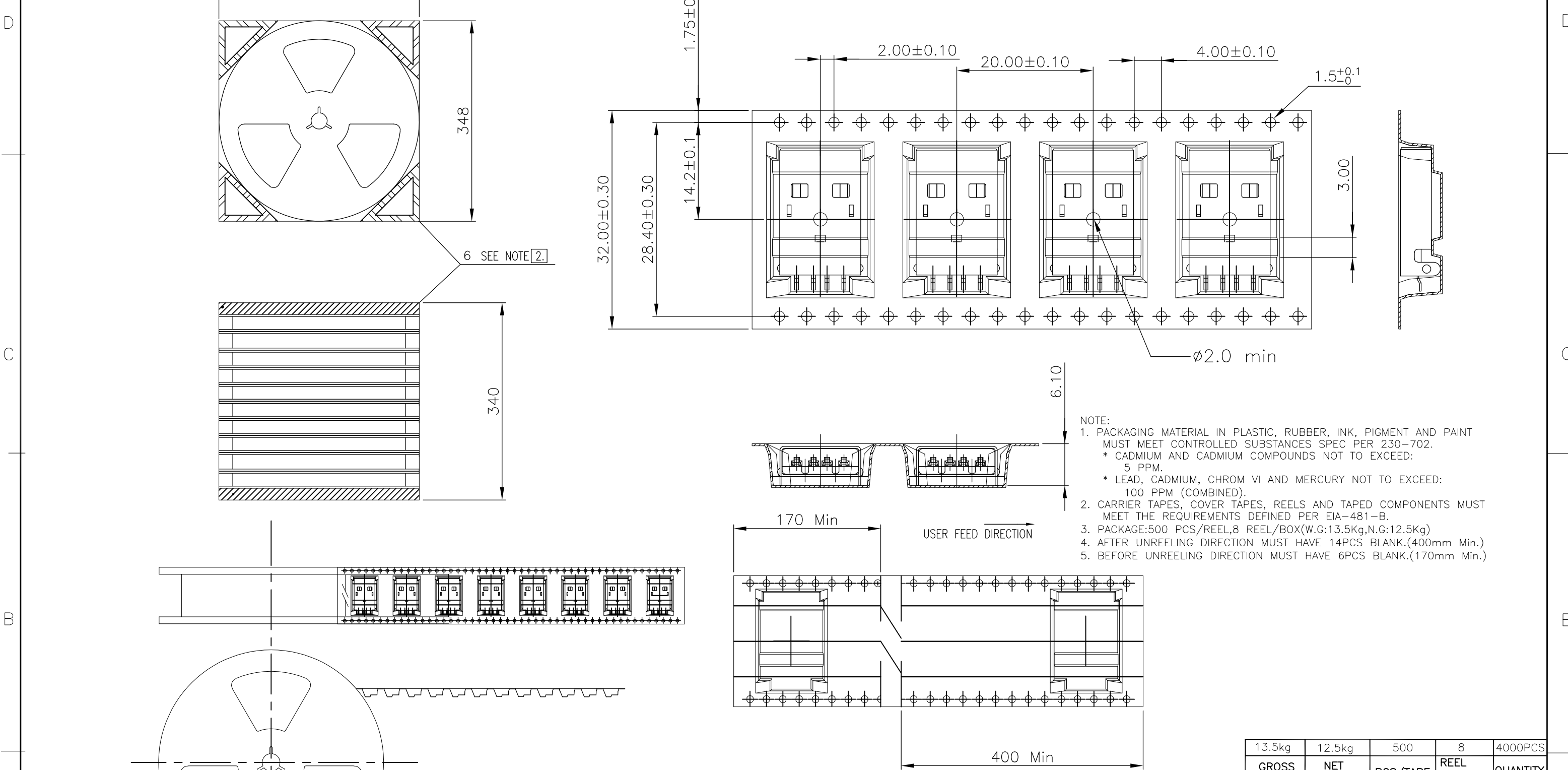

13.5kg	12.5kg	500	8	4000PCS
GROSS WEIGHT	NET WEIGHT	PCS/TAPE	REEL / CARTON	QUANTITY

THIS DRAWING IS A CONTROLLED DOCUMENT.		DWN	Tyco Electronics Corporation Taipei, Taiwan		
DIMENSIONS: MM		CHK	NAME		
TOLERANCES UNLESS OTHERWISE SPECIFIED:		APVD	USB CONNECTOR, PLUG, R/A, SMT TYPE		
0 PLC ± -		PRODUCT SPEC	SIZE CAGE CODE DRAWING NO RESTRICTED TO		
1 PLC ± -		APPLICATION SPEC	A3 00779 C-1734028		
2 PLC ± -		WEIGHT	CUSTOMER DRAWING		
3 PLC ± -			SCALE SHEET 3 OF 3 REV B1		
4 PLC ± -					
ANGLES ± -					
FINISH					
MATERIAL					