

THIS DRAWING IS UNPUBLISHED. RELEASED FOR PUBLICATION

© COPYRIGHT BY TYCO ELECTRONICS CORPORATION. ALL RIGHTS RESERVED.

LOC	DIST	REVISIONS					
FT	0	P	LTR	DESCRIPTION	DATE	DWN	APVD
			A	-	11/16/06	SS	SRY

MATERIAL:
 HOUSING: NYLON, UL94V-0, BLACK.
 TERMINALS: BRASS, BRIGHT TIN PLATED.
 SCREWS: 6-32, STEEL, ZINC CHROMATE FINISH.

ELECTRICAL:
 MAXIMUM CURRENT: 20A
 OPERATING VOLTAGE: 600V
 WIRE RANGE: 12-22 AWG

ENVIRONMENT:
 OPERATING TEMP.: -60°C TO +105°C

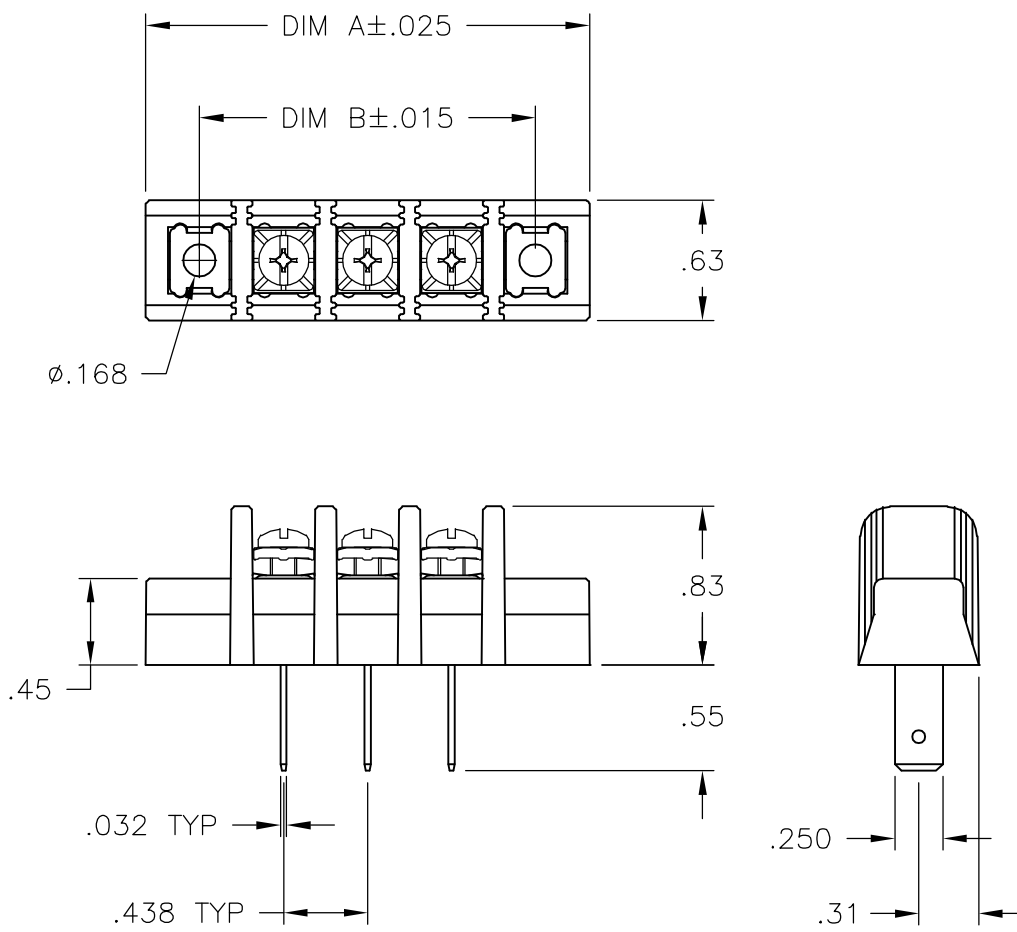

11.375	11.937	25	SSB7FG250502	2-1546971-5
10.937	11.500	24	SSB7FG240502	2-1546971-4
10.500	11.062	23	SSB7FG230502	2-1546971-3
10.062	10.625	22	SSB7FG220502	2-1546971-2
9.625	10.187	21	SSB7FG210502	2-1546971-1
9.187	9.750	20	SSB7FG200502	2-1546971-0
8.750	9.312	19	SSB7FG190502	1-1546971-9
8.312	8.875	18	SSB7FG180502	1-1546971-8
7.875	8.437	17	SSB7FG170502	1-1546971-7
7.437	8.000	16	SSB7FG160502	1-1546971-6
7.000	7.562	15	SSB7FG150502	1-1546971-5
6.562	7.125	14	SSB7FG140502	1-1546971-4
6.125	6.687	13	SSB7FG130502	1-1546971-3
5.687	6.250	12	SSB7FG120502	1-1546971-2
5.250	5.812	11	SSB7FG110502	1-1546971-1
4.812	5.375	10	SSB7FG100502	9-796602-5
4.375	4.937	9	SSB7FG090502	1546971-9
3.937	4.500	8	SSB7FG080502	1546971-8
3.500	4.062	7	SSB7FG070502	1546971-7
3.062	3.625	6	SSB7FG060502	1546971-6
2.625	3.187	5	SSB7FG050502	9-796602-3
2.187	2.750	4	SSB7FG040502	1546971-4
1.750	2.312	3	SSB7FG030502	1546971-3
1.312	1.875	2	SSB7FG020502	1546971-2
.875	1.437	1	SSB7FG010502	1546971-1
DIM B	DIM A	NO. OF POS.	CATALOG NUMBER	PART NUMBER

THIS DRAWING IS A CONTROLLED DOCUMENT.		DWN S SCHL GEL 11/16/06	Tyco Electronics Corporation Harrisburg, PA 17105-3608		
DIMENSIONS: INCHES		CHK S YODER 11/16/06			
TOLERANCES UNLESS OTHERWISE SPECIFIED:		APVD S YODER 11/16/06	NAME SSB7FGXX0502		
0 PLC ± - 1 PLC ± - 2 PLC ± .02 3 PLC ± .010 4 PLC ± - ANGLES ± 1°		PRODUCT SPEC -	RESTRICTED TO -		
MATERIAL -		APPLICATION SPEC -	SIZE A3	CAGE CODE 00779	DRAWING NO C-9-796602-3
FINISH -		WEIGHT -	SCALE NTS		SHEET 1 OF 1
CUSTOMER DRAWING			REV A		