

THIS DRAWING IS UNPUBLISHED. RELEASED FOR PUBLICATION
 © COPYRIGHT BY TYCO ELECTRONICS CORPORATION. ALL RIGHTS RESERVED.

LOC	DIST	REVISIONS					
FT	0	P	LTR	DESCRIPTION	DATE	DWN	APVD
		-	-	SEE SHEET 1	-	-	-

DOUBLE SIDED, DOUBLE HOLE
QC TAB, QTY 5

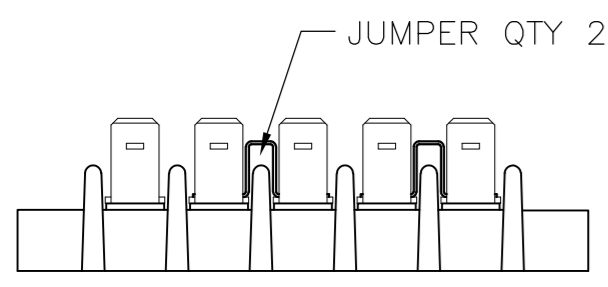
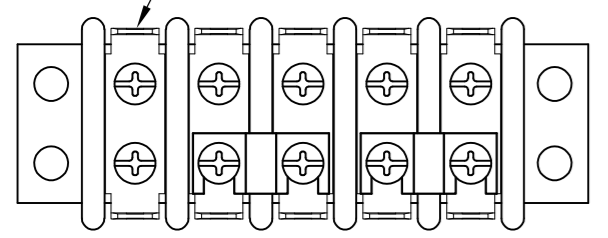

2-1546670-7

DOUBLE SIDED, DOUBLE HOLE
QC TAB, QTY 5

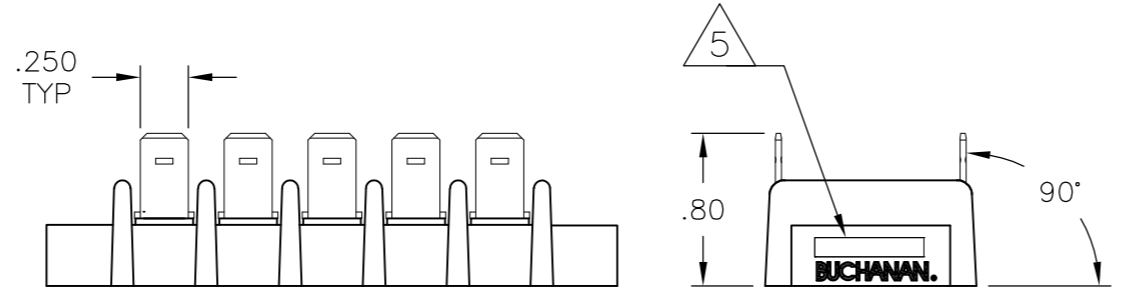
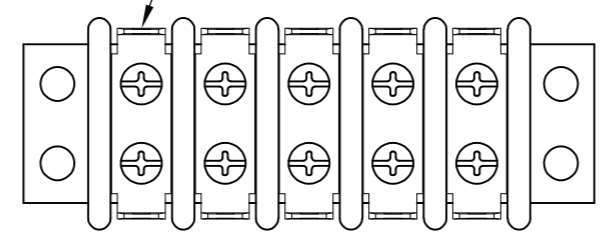

2-1546670-8

JUMPER, QTY 1

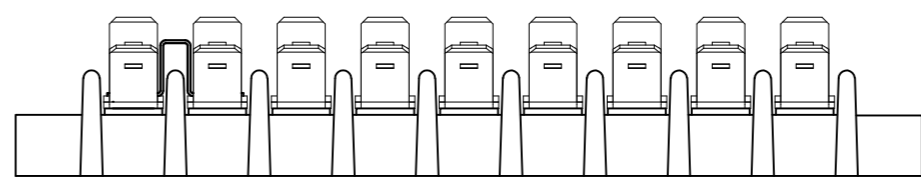
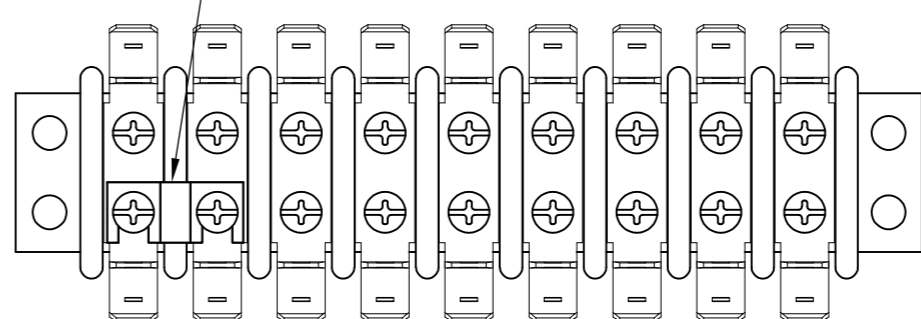

3-1546670-2

DOUBLE SIDED, DOUBLE HOLE
45° QC TAB, QTY 9

DOUBLE SIDED, DOUBLE HOLE
90° QC TAB, QTY 9

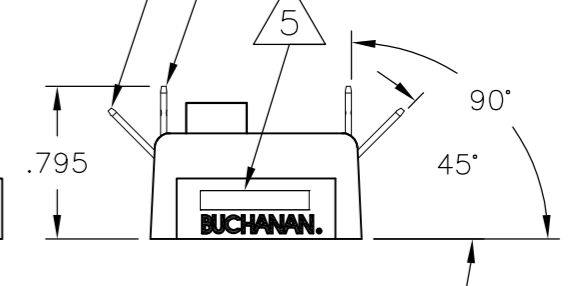

DOUBLE SIDED, DOUBLE HOLE
QC TAB, QTY 5

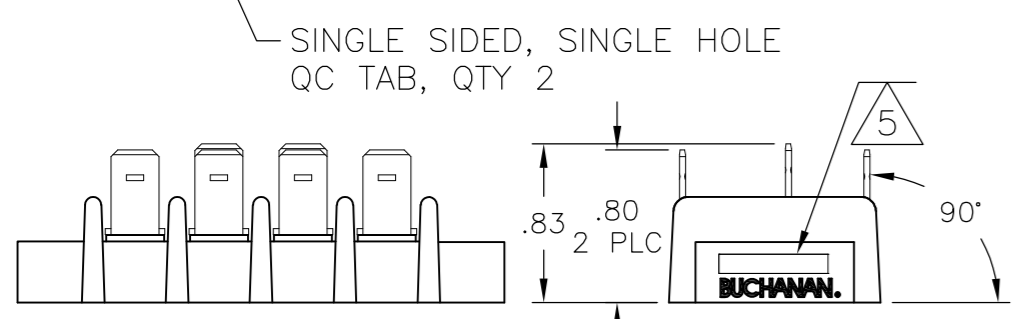
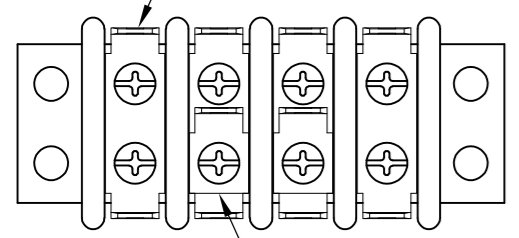

2-1546670-9

SINGLE SIDED, DOUBLE HOLE
QC TAB, QTY 6

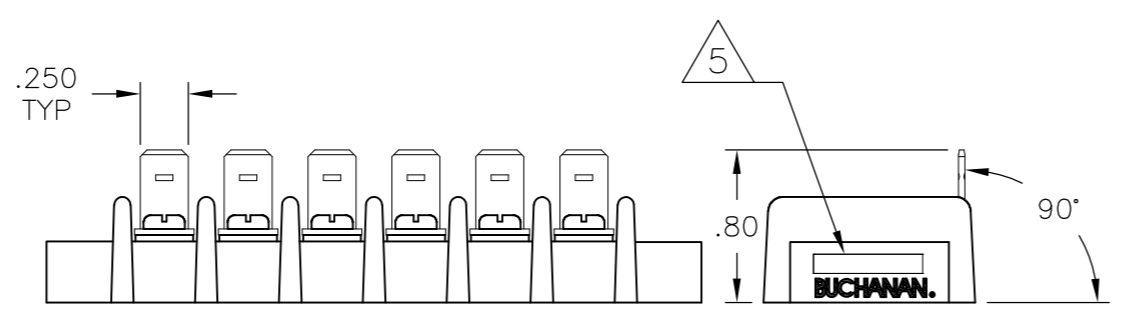
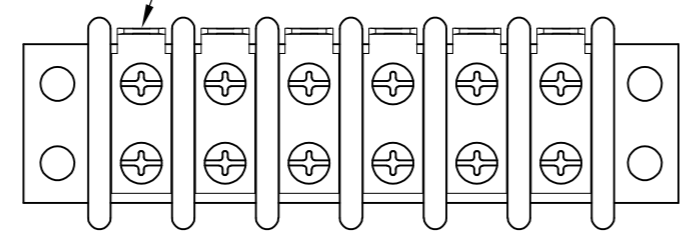

3-1546670-1

DOUBLE SIDED, DOUBLE HOLE
FLAT QC TAB, QTY 8.

JUMPER, QTY 2

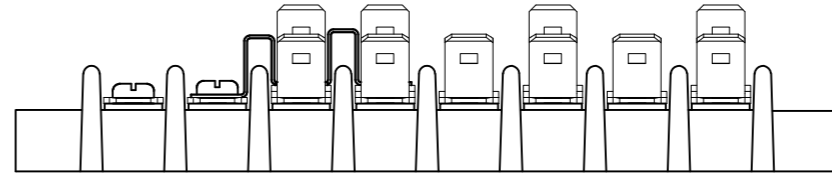
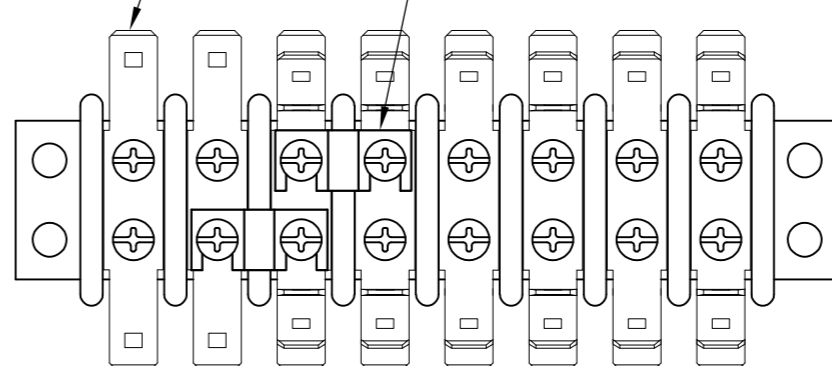

3-1546670-3

DOUBLE SIDED, DOUBLE HOLE
45° QC TAB, QTY 6

DOUBLE SIDED, DOUBLE HOLE
90° QC TAB, QTY 4

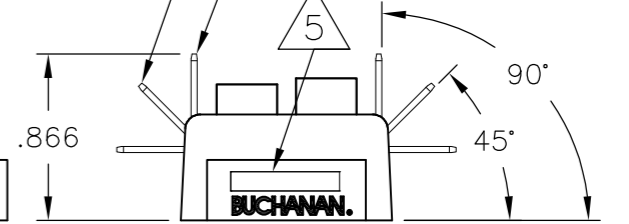

SINGLE SIDED, DOUBLE HOLE
QC TAB, QTY 18

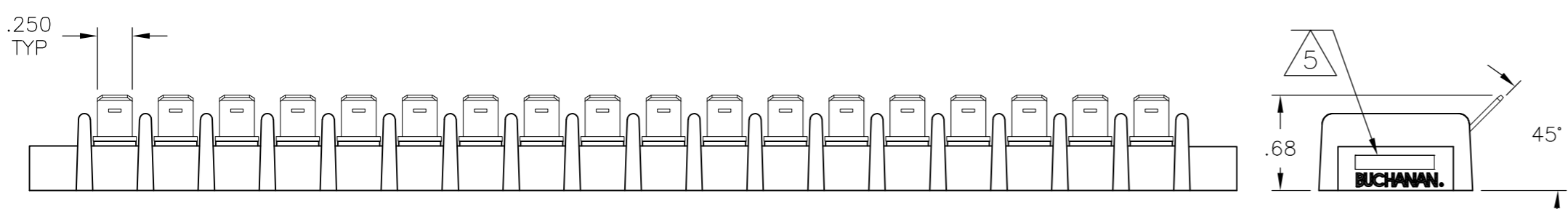
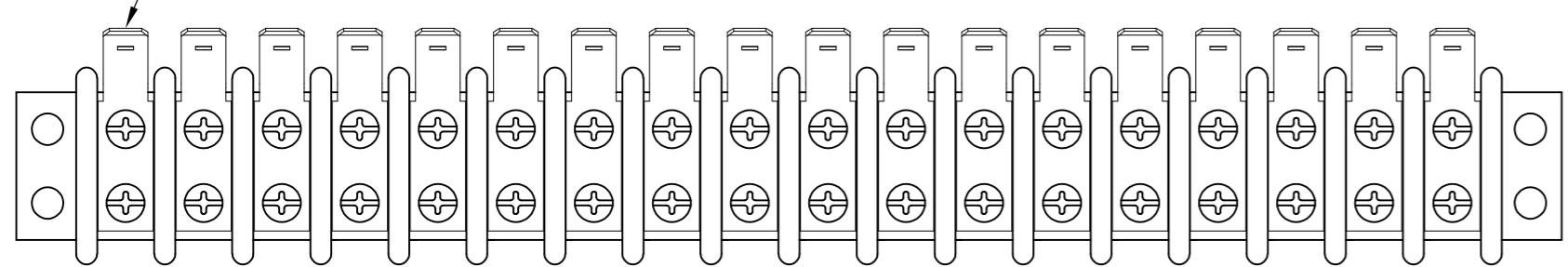

3-1546670-0

DOUBLE SIDED, DOUBLE HOLE
FLAT QC TAB, QTY 8.

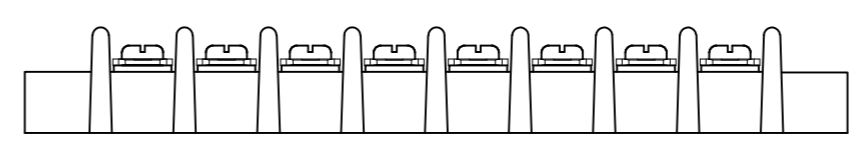
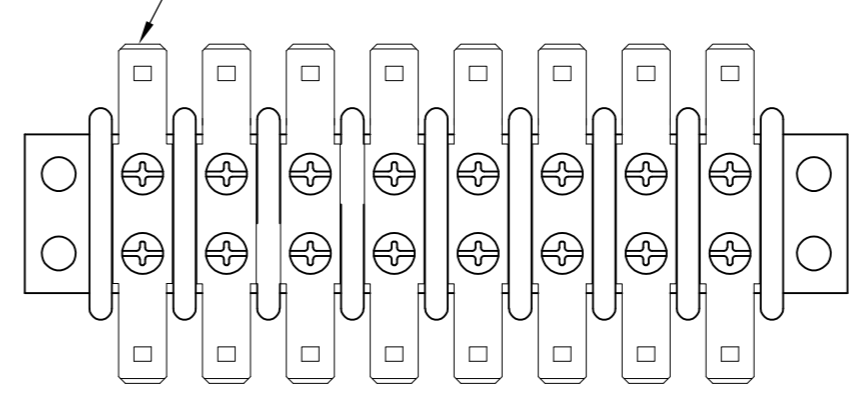

3-1546670-4

11.764	12.110	26	2-1546670-6
11.327	11.673	25	2-1546670-5
10.90	11.236	24	2-1546670-4
10.453	10.799	23	2-1546670-3
10.016	10.362	22	2-1546670-2
9.579	9.925	21	2-1546670-1
9.142	9.488	20	3-1546670-7
DIM B	DIM A	NO OF POS	PART NUMBER

THIS DRAWING IS A CONTROLLED DOCUMENT.

DWN	S SCHEGEL	4/4/03
CHK	C RICHARD	4/4/03
APVD	C RICHARD	4/4/03
PRODUCT SPEC		
APPLICATION SPEC		
WEIGHT		
CUSTOMER DRAWING		

TOLERANCES UNLESS OTHERWISE SPECIFIED:
 0 PLC ± -
 1 PLC ± -
 2 PLC ± .01
 3 PLC ± .005
 4 PLC ± -
 ANGLES ± 3°
 FINISH -

Tyco Electronics Tyco Electronics Corporation
 Harrisburg, PA 17105

NAME: DOUBLE ROW BARRIER STRIP W/ BINDING HD SCREW, .437 SPACING

SIZE	CAGE CODE	DRAWING NO	RESTRICTED TO
A2	00779	C=1546670	-
SCALE	NTS	SHEET	2 OF 3
REV	K17		

THIS DRAWING IS UNPUBLISHED. RELEASED FOR PUBLICATION
 © COPYRIGHT BY TYCO ELECTRONICS CORPORATION. ALL RIGHTS RESERVED.

LOC	DIST	REVISIONS					
FT	0	P	LTR	DESCRIPTION	DATE	DWN	APVD
				SEE SHEET 1			

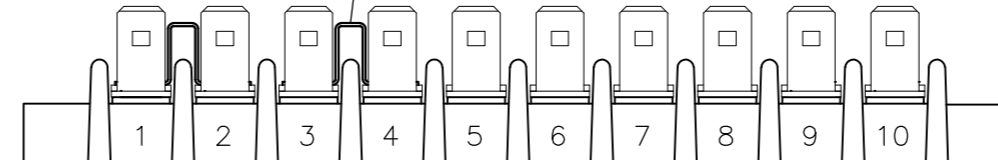
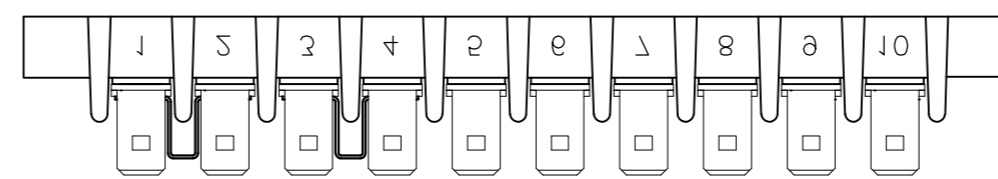
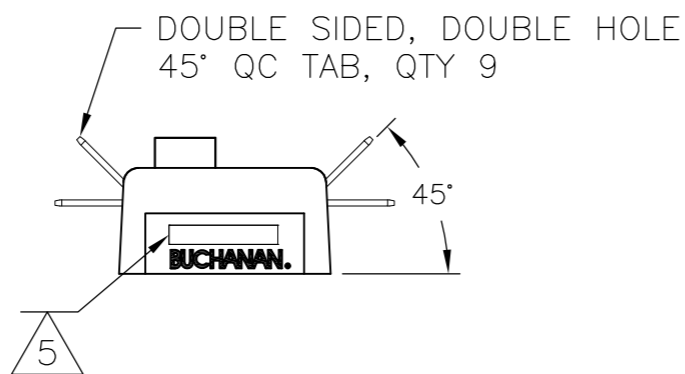
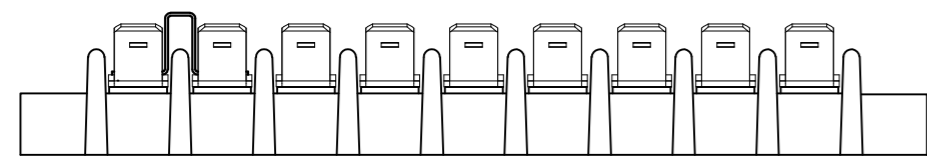
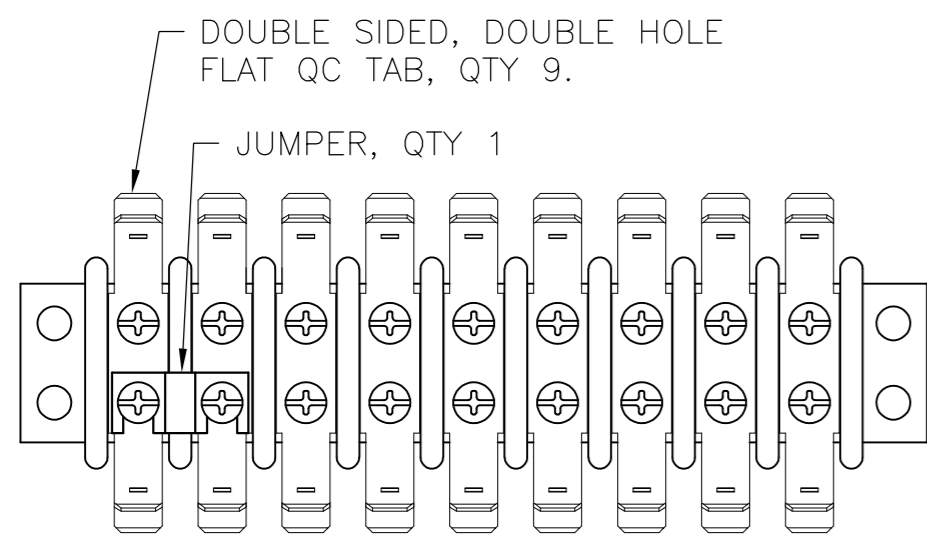

SINGLE SIDED, DOUBLE HOLE 45° QC TAB, QTY 10

SINGLE SIDED, DOUBLE HOLE 90° QC TAB, QTY 10

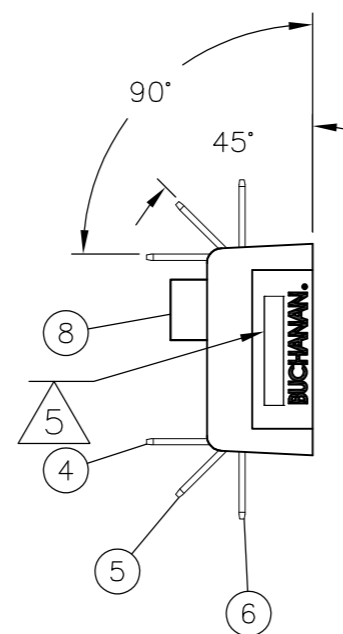
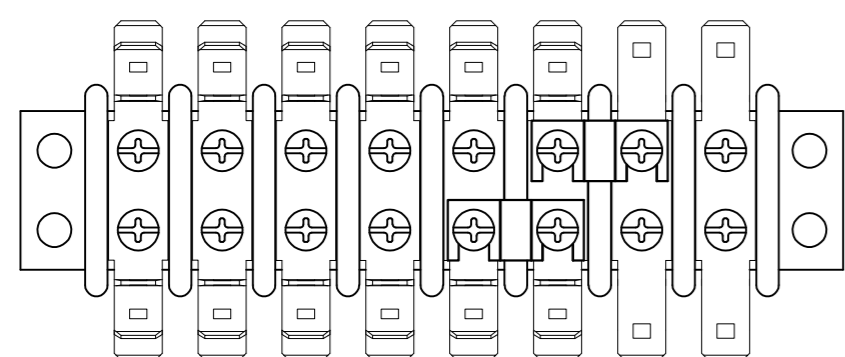
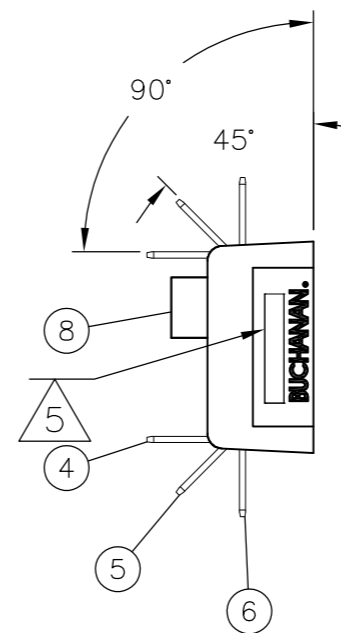
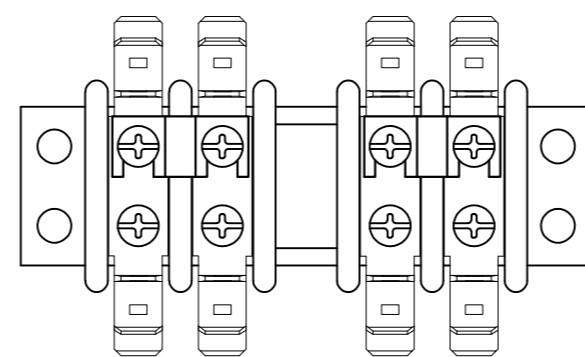
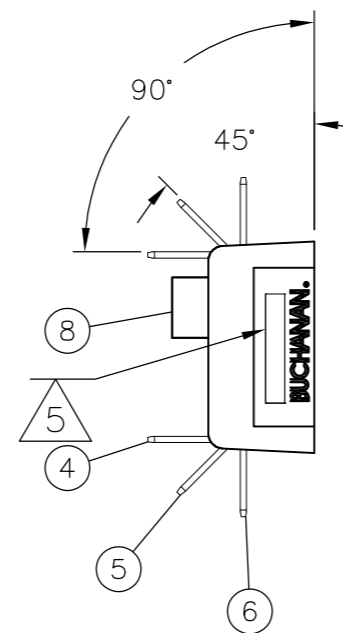
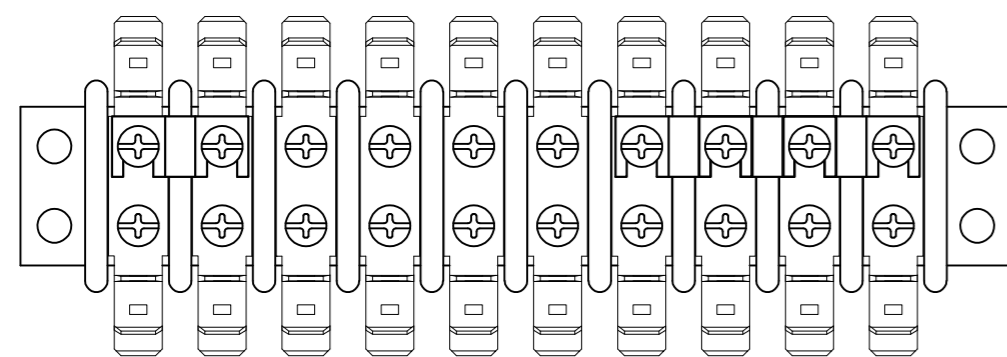
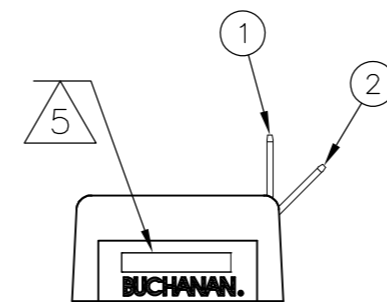
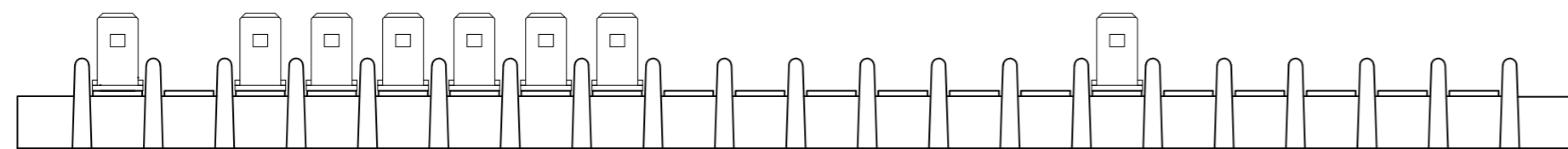
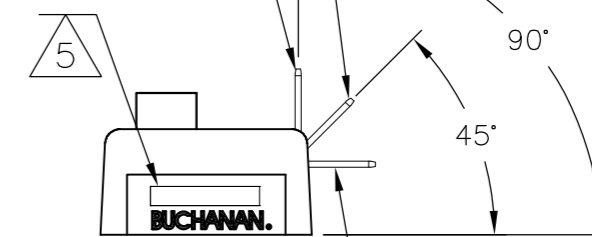

THIS DRAWING IS A CONTROLLED DOCUMENT.		DWN S SCHEGEL 4/4/03	Tyco Electronics Corporation Harrisburg, PA 17105	
DIMENSIONS: INCHES		CHK C RICHARD 4/4/03		
TOLERANCES UNLESS OTHERWISE SPECIFIED:		APVD C RICHARD 4/4/03	NAME DOUBLE ROW BARRIER STRIP W/ BINDING HD SCREW, .437 SPACING	
0 PLC ± - 1 PLC ± - 2 PLC ± .01 3 PLC ± .005 4 PLC ± - ANGLES ± 3°		PRODUCT SPEC -	SIZE A2	CAGE CODE 00779
MATERIAL -		FINISH -	DRAWING NO C=1546670	RESTRICTED TO -
CUSTOMER DRAWING		WEIGHT -	SCALE NTS	SHEET 3 OF 3
			REV K17	

1546670