

# SERPAC WM023-RI (exploded isometric)

Electronic Enclosures

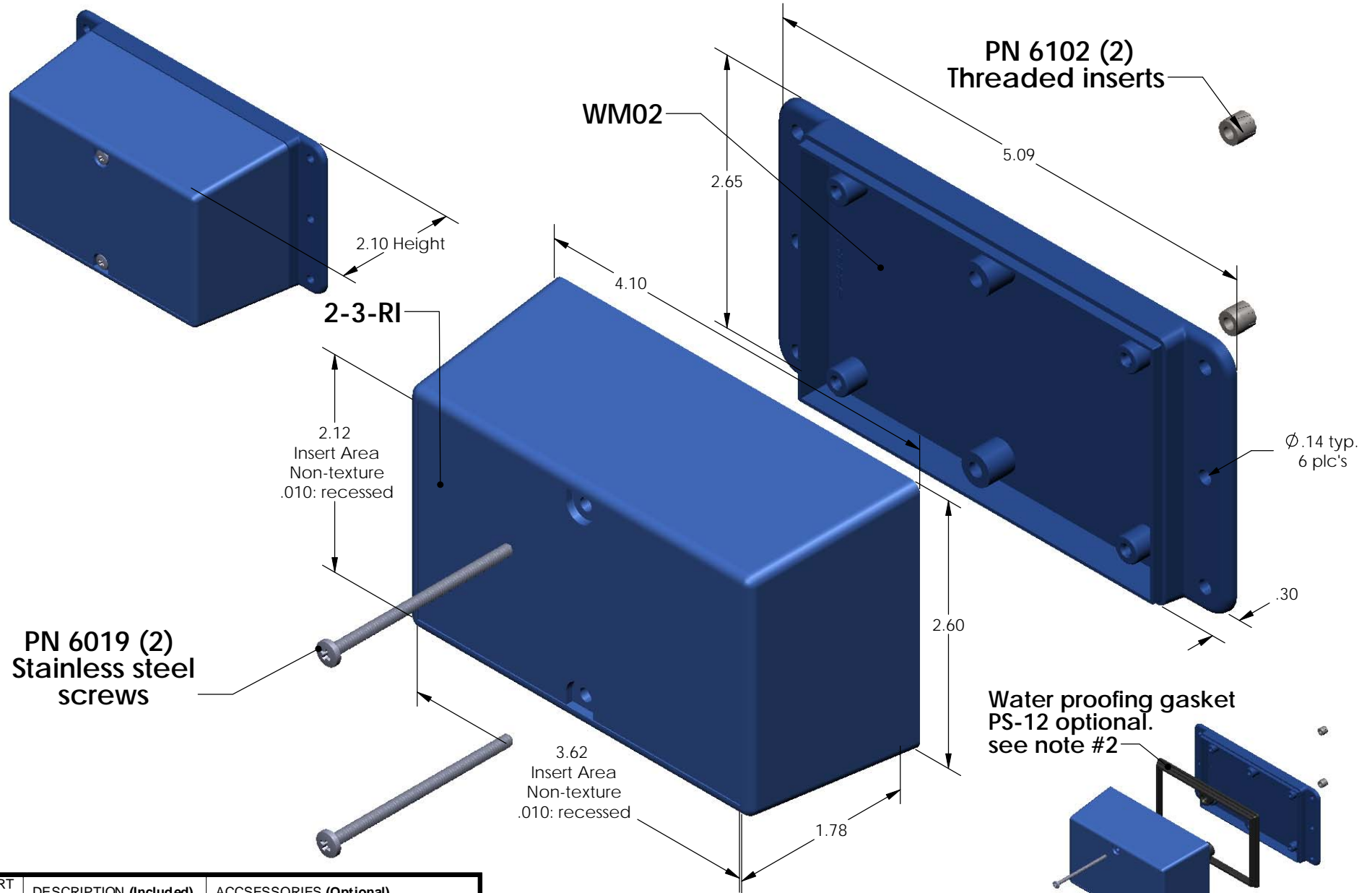

PART NO.	DESCRIPTION (Included)	ACCESSORIES (Optional)	
2-3-RI	TOP	PART NO.	DESCRIPTION
WM02	BOTTOM	PS-12	Perimeter Seal
6019	4-40 SCREW (2)		
6102	THREADED INSERTS (2)		

Notes:

- 1) Enclosure meets or exceeds IP40 and NEMA 1
- 2) When used with PS-12 the enclosure meets or exceeds IP 67 and NEMA 4X, 12 and 13 MIL-STD-810G 506.5
- 3) Circuit Board drawings can be download at:  
[http://www.serpac.com/Products/Accessories/CircuitBoard/drawings/CB\\_WM023.pdf](http://www.serpac.com/Products/Accessories/CircuitBoard/drawings/CB_WM023.pdf)
- 4) All components are RoHS Compliant.

Water proofing gasket  
PS-12 optional.  
see note #2

# SERPAC WM023-RI (user print)

Electronic Enclosures

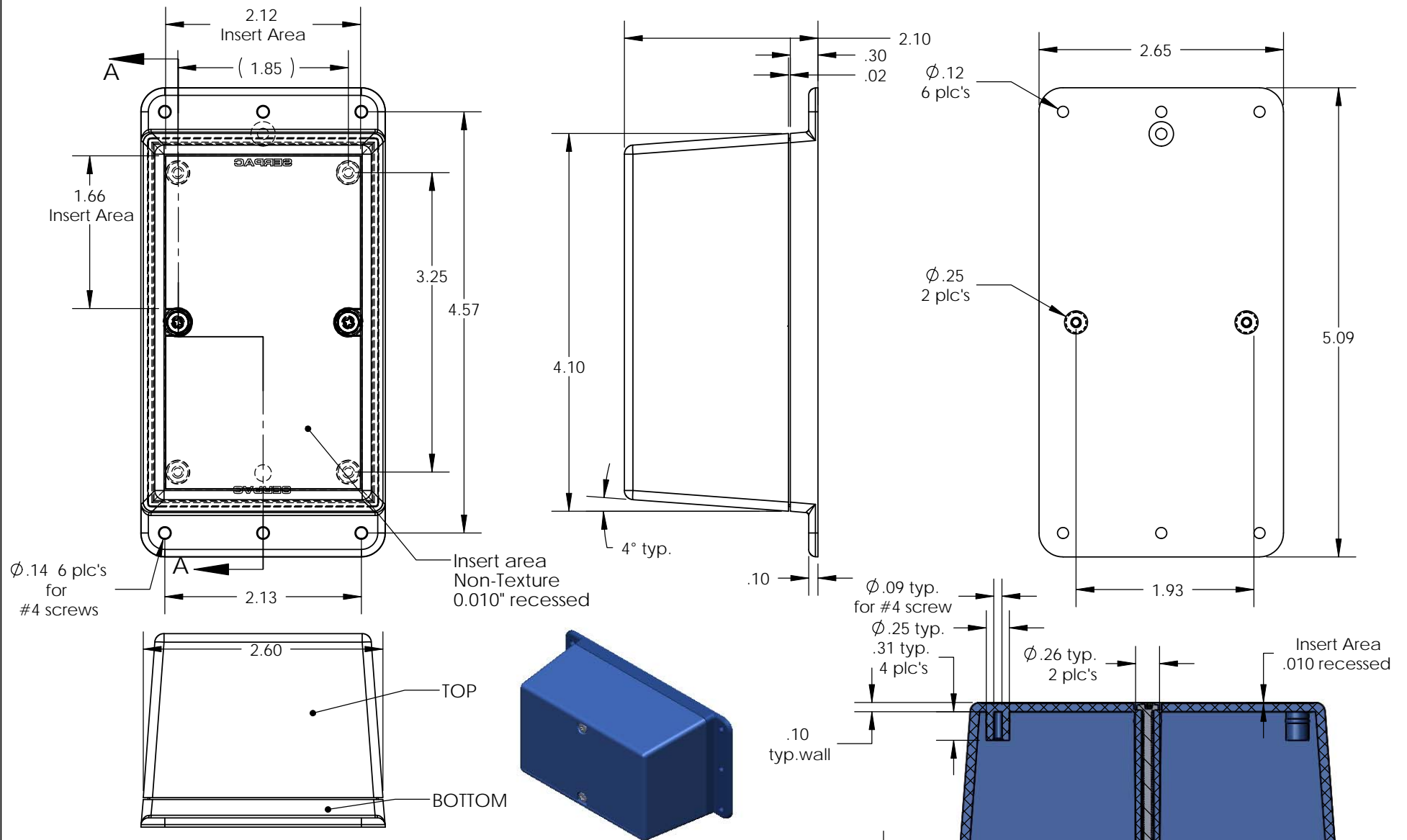

**Notes:**

- 1) Enclosure meets or exceeds IP40 and NEMA 1
- 2) When used with PS-12 the enclosure meets or exceeds IP 67 and NEMA 4X, 12 and 13 MIL-STD-810G 506.5
- 3) Circuit Board drawings can be download at: [http://www.serpac.com/Products/Accessories/CircuitBoard/drawings/CB\\_WM023.pdf](http://www.serpac.com/Products/Accessories/CircuitBoard/drawings/CB_WM023.pdf)
- 4) All components are RoHS Compliant.

PART NO.	DESCRIPTION (Included)	ACCESSORIES (Optional)	
2-3-RI	TOP	PART NO.	DESCRIPTION
WM02	BOTTOM	PS-12	Perimeter Seal
6019	4-40 SCREW (2)		
6102	THREADED INSERTS (2)		

SECTION A-A  
SCALE 1 : 1.5