

| No. OF PINS | DIMENSIONS | | | | | | | |
|-------------|------------|-------|-------|-------|-------|-------|-------|-------|
| | A | B | C | D | E | F | G | H |
| 9 | 1.213 | 0.984 | 0.666 | 0.329 | 0.236 | 0.756 | 0.496 | 0.427 |
| | 30.80 | 24.99 | 16.92 | 8.36 | 5.99 | 19.20 | 12.60 | 10.85 |
| 15 | 1.541 | 1.312 | 0.994 | 0.329 | 0.236 | 1.091 | 0.496 | 0.427 |
| | 39.15 | 33.32 | 25.25 | 8.36 | 5.99 | 27.70 | 12.60 | 10.85 |
| 25 | 2.087 | 1.852 | 1.534 | 0.329 | 0.236 | 1.618 | 0.496 | 0.427 |
| | 53.00 | 47.04 | 38.96 | 8.36 | 5.99 | 41.10 | 12.60 | 10.85 |

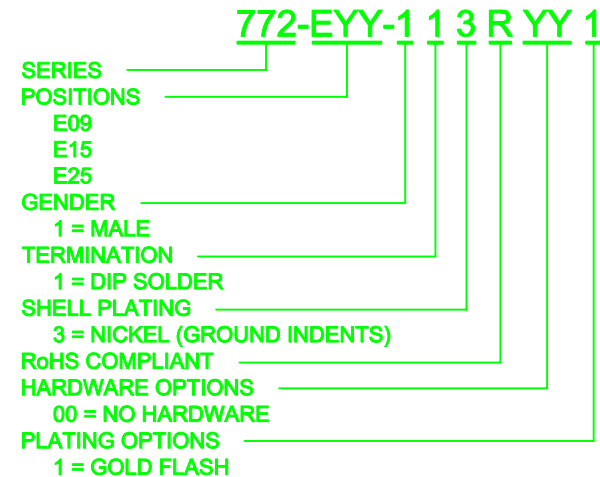
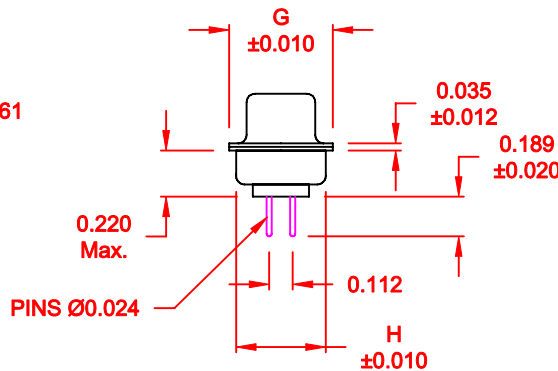
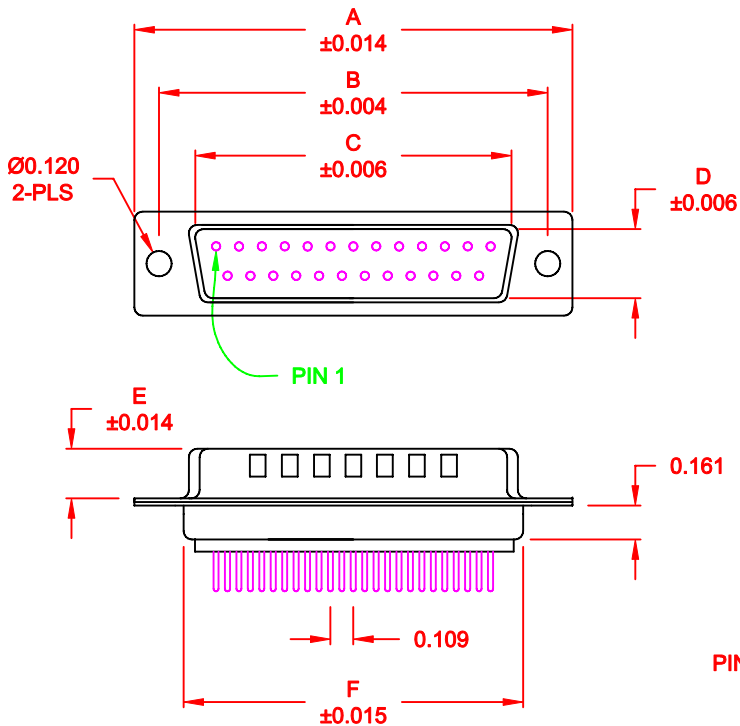

MATERIAL:

SHELL: STEEL, NICKEL PLATED
 INSULATOR: UL 94V-O RATED, WHITE PA6T
 PROCESS TEMP.: 260° C
 CONTACT: BRASS
 SEALING MATERIAL: F08 FLEXIBLE ADHESIVE

ELECTRICAL:

CURRENT RATING: 5 AMPS
 CONTACT RESISTANCE: 15 mOhms Max.
 INSULATION RESISTANCE: 1,000 MOhms min.
 VOLTAGE: 500VAC FOR 1 MINUTE
 TEMPERATURE: -50° C TO 100° C

MEETS IP67 STANDARDS

(SEE PAGE 3 FOR SEALING DETAILS)

DO NOT SCALE FROM DRAWING

RoHS COMPLIANT

| | | | | |
|--|---|--------------|--------------------|---------------|
|  | THESE DRAWINGS AND SPECIFICATIONS ARE THE PROPERTY OF NorComp AND SHALL NOT BE REPRODUCED, COPIED OR USED AS THE BASIS FOR THE MANUFACTURE OF SALE OF APPARATUS WITHOUT WRITTEN PERMISSION. | | DRAWN: PAM JENKINS | DATE: 9-18-08 |
| | NorComp | | | CHECKED: |
| SCALE: 1:1 | | SHEET 1 OF 3 | REV 1 | |
| DWG NO. 772-EYY-113RYY1 | | | | |

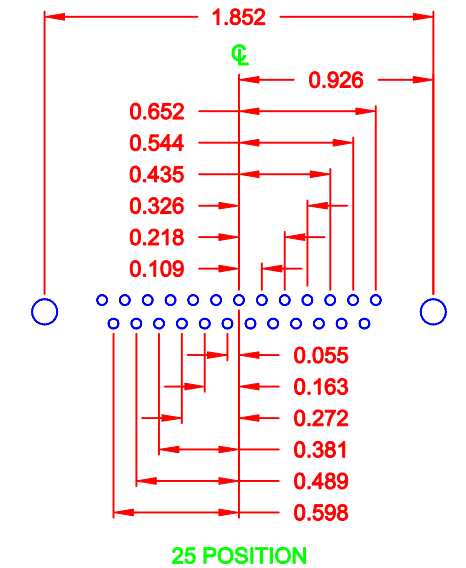
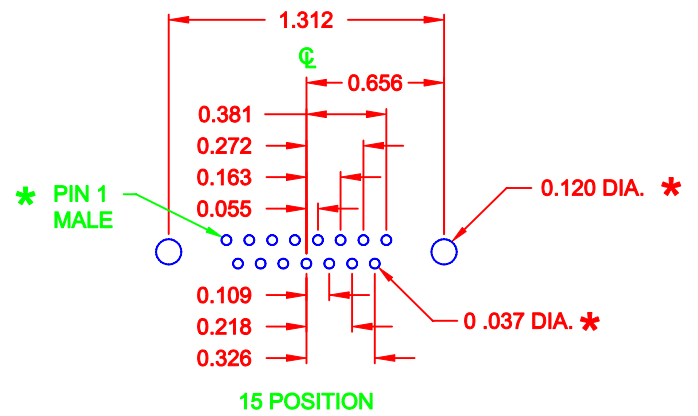
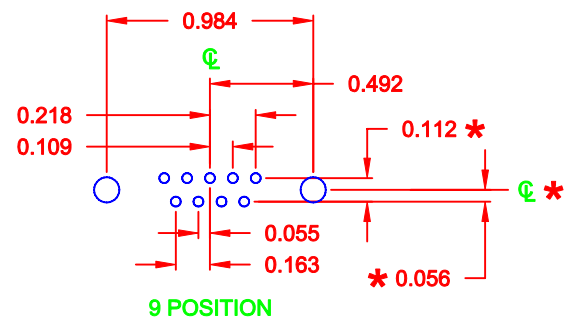

* TYP. ON ALL SIZES

DO NOT SCALE FROM DRAWING

| | | | | |
|--|---|--------------------------------|------------------------------|-------------------------|
|  | THESE DRAWINGS AND SPECIFICATIONS ARE THE PROPERTY OF NorComp AND SHALL NOT BE REPRODUCED, COPIED OR USED AS THE BASIS FOR THE MANUFACTURE OF SALE OF APPARATUS WITHOUT WRITTEN PERMISSION. | | DRAWN: PAM JENKINS | DATE: 9-18-08 |
| | | | CHECKED: | DATE: |
| <h1>NorComp</h1> | | SCALE: FULL | SHEET 2 OF 3 | REV 1 |
| | | DWG NO. 772-EYY-113RYY1 | | |

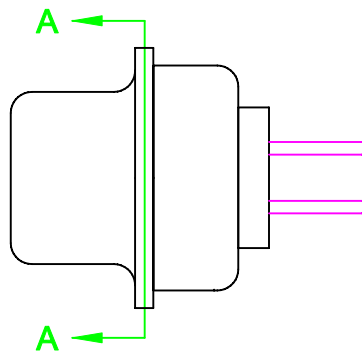

FRONT SEAL APPLIED OVER INSULATOR AND BETWEEN FRONT & REAR SHELLS

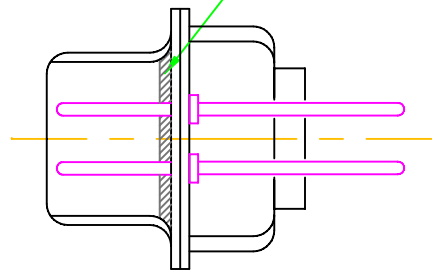

DETAIL A-A

DO NOT SCALE FROM DRAWING

| | | | | |
|--|---|--------------------------------|-------------------------------|--------------------------|
|  | THESE DRAWINGS AND SPECIFICATIONS ARE THE PROPERTY OF NorComp AND SHALL NOT BE REPRODUCED, COPIED OR USED AS THE BASIS FOR THE MANUFACTURE OF SALE OF APPARATUS WITHOUT WRITTEN PERMISSION. | | DRAWN: C. SMITH | DATE: 06-10-09 |
| | | | CHECKED: | DATE: |
| NorComp | | SCALE: 2.5 : 1 | SHEET 3 OF 3 | REV 1 |
| | | DWG NO. 772-EYY-113RYY1 | | |