

Tous droits strictement réservés. Reproduction ou communication à des tiers interdite sous quelque forme que ce soit sans autorisation écrite du Propriétaire de c FCI. Droits de reproduction FCI.  
 All rights strictly reserved. Reproduction or issue to third parties in any form whatever is not permitted without written authority from the proprietor. Property of FCI. Copyright FCI.

PRODUCT NO.  
69830

REVISIONS			
REV	DESCRIPTION	BY	DATE
B	ECR LB277	HS	5/12/86
C	EC T20212		10/22/92
D	N05-0038	Jason	2/17/05
E	N05-0056	Jason	3/1/05

PRODUCT NO.	COVER P/N	BASE ASSY P/N	NO. OF POSITION	A	B	C
69830-006(LF)	68118-006	69831-006(LF)	6	12.08	6.35	5.08
69830-008(LF)	68118-008	69831-008(LF)	8	14.62	8.89	7.62
69830-010(LF)	68118-010	69831-010(LF)	10	17.16	11.43	10.16
69830-014(LF)	68118-014	69831-014(LF)	14	22.24	16.51	15.24
69830-016(LF)	68118-016	69831-016(LF)	16	24.78	19.05	17.78
69830-018(LF)	68118-018	69831-018(LF)	18	27.32	21.59	20.32
69830-020(LF)	68118-020	69831-020(LF)	20	29.86	24.13	22.86
69830-024(LF)	68118-024	69831-024(LF)	24	34.94	29.21	27.94
69830-026(LF)	68118-026	69831-026(LF)	26	37.48	31.75	30.48
69830-030(LF)	68118-030	69831-030(LF)	30	42.56	36.83	35.56
69830-034(LF)	68118-034	69831-034(LF)	34	47.64	41.91	40.64
69830-040(LF)	68118-040	69831-040(LF)	40	55.26	49.53	48.26
69830-050(LF)	68118-050	69831-050(LF)	50	67.96	62.23	60.96
69830-060(LF)	68118-060	69831-060(LF)	60	80.56	74.93	73.66
69830-064(LF)	68118-064	69831-064(LF)	64	85.74	80.01	78.74

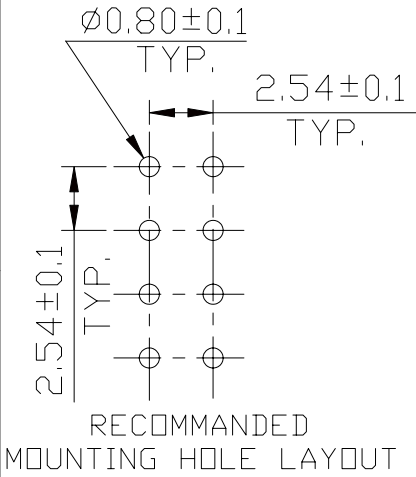

- NOTES:
- ① SEE TABLE.
  - ② MATERIAL:  
 BASE  POLYESTER (PET) GLASS  
 COVER  30% FILLED, UL94V-0, COLOR: BLUE.  
 TERMINAL  PHOSPHOR BRONZE.
  - 3. FINISH:  
 69830-\*\*\*: ALL OVER SnPb PLATING 3.81um MIN. 1.27 um MIN. Ni UNDER PLATING.  
 69830-\*\*\*LF: ALL OVER PURE Sn PLATING 3.81um MIN. 1.27 um MIN. Ni UNDER PLATING.
  - 4. APPLICABLE SPECIFICATIONS:  
 PRODUCT SPEC 110-019  
 CRIMPING (I.D.C) SPEC 100-004.
  - 5. CONTACT RETENSION FORCE:  
 400gf/pin MIN. AGAINST THIS DIRECTION.
  - 6. THE HOUSING OF XXXX-XYLF WILL WITHSTAND EXPOSURE TO 260°C PEAK TEMPERATURE FOR 5 SECONDS IN A WAVE SOLDER APPLICATION.

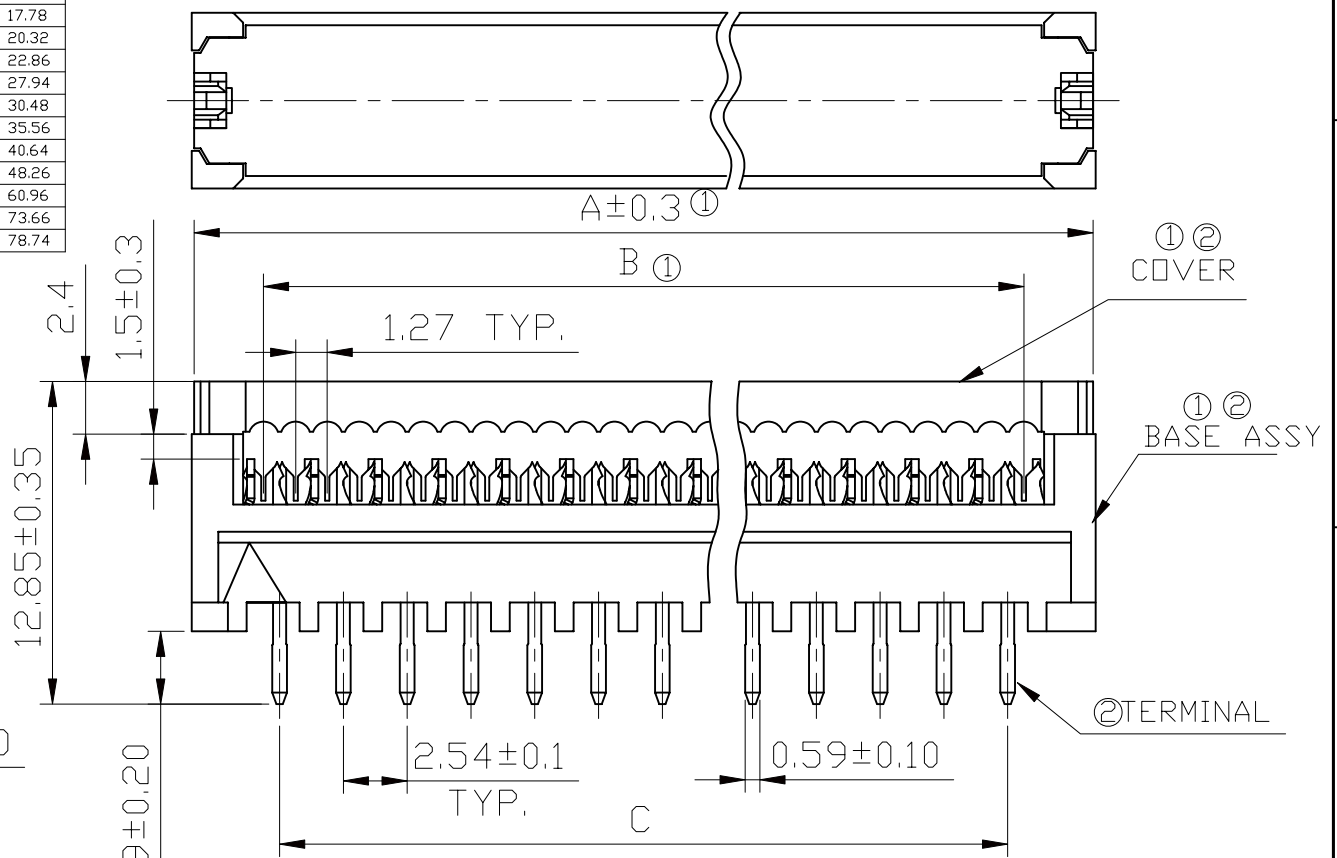

mat'l. code		tolerances unless otherwise specified		CUSTOMER COPY		 www.fciconnect.com	
ltr	ecn no	dr	date	linear	.X ± 0.3	projection	 title <b>QUICKIE DIL PCB CONNECTOR (.100 SHORT LEG)</b>
D	N05-0038	ZC	2/17/05		.XX ± 0.15		
E	N05-0056	ZC	3/1/05	angles	.XXX ± 0.05	 MM scale 1:1	product family <b>QUICKIE</b> size 69830 code sheet 1 of 1
				dr	X.±2'		
				enr	Zhengcai Tao 2/17/05		
				chr	Zhengcai Tao 2/17/05		
				appd	Jason Zhou 2/17/05		
sheet index	revision sheet						