

I

2

3

4

A

A

B

B

C

C

D

D

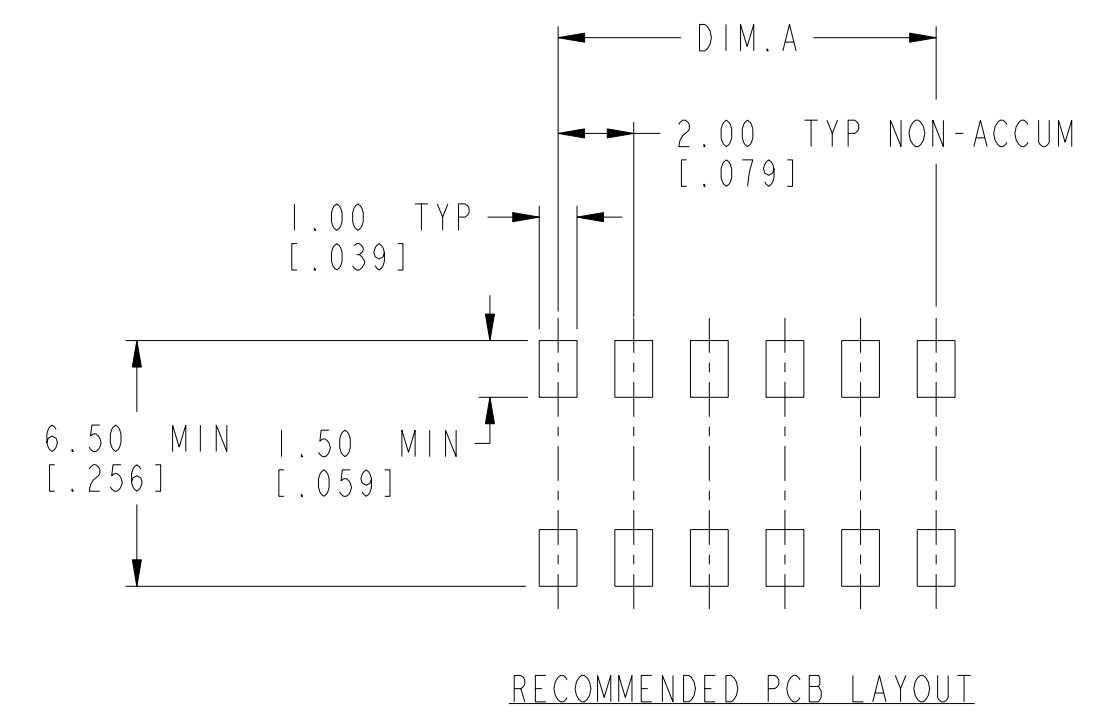
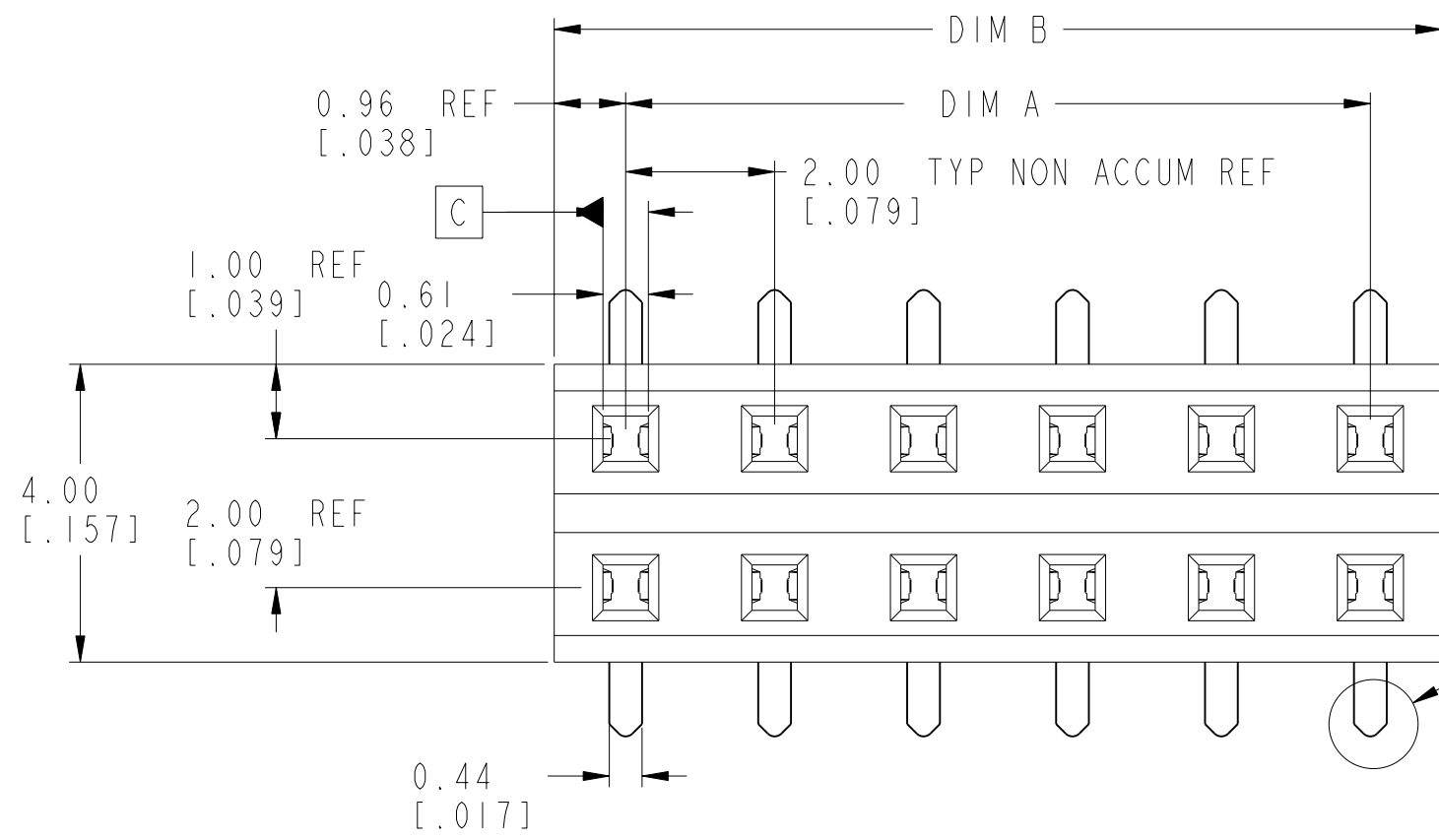

DETAIL NOTE 4

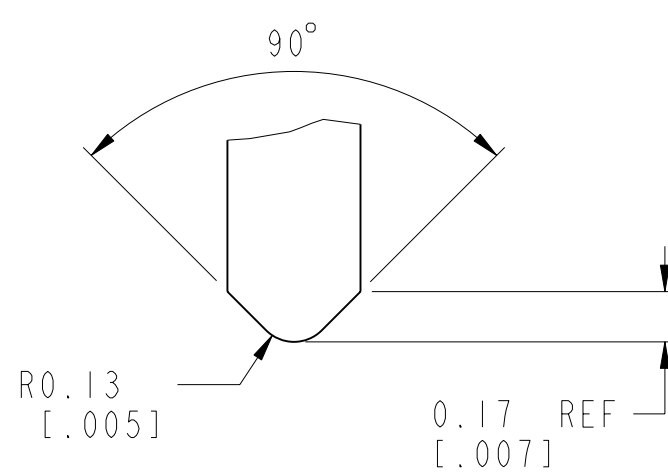
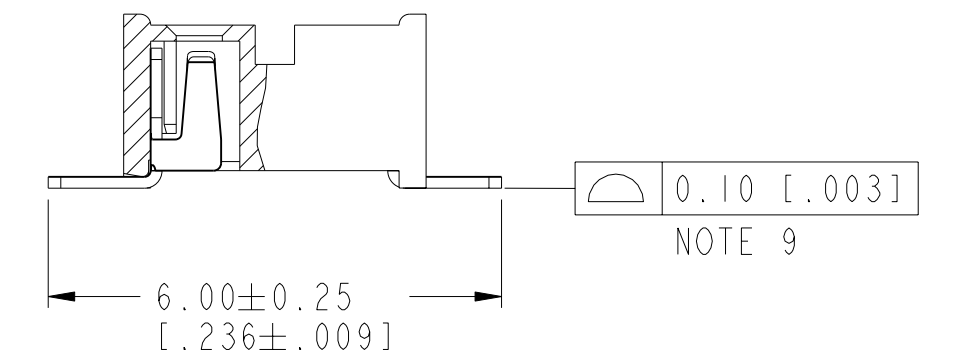
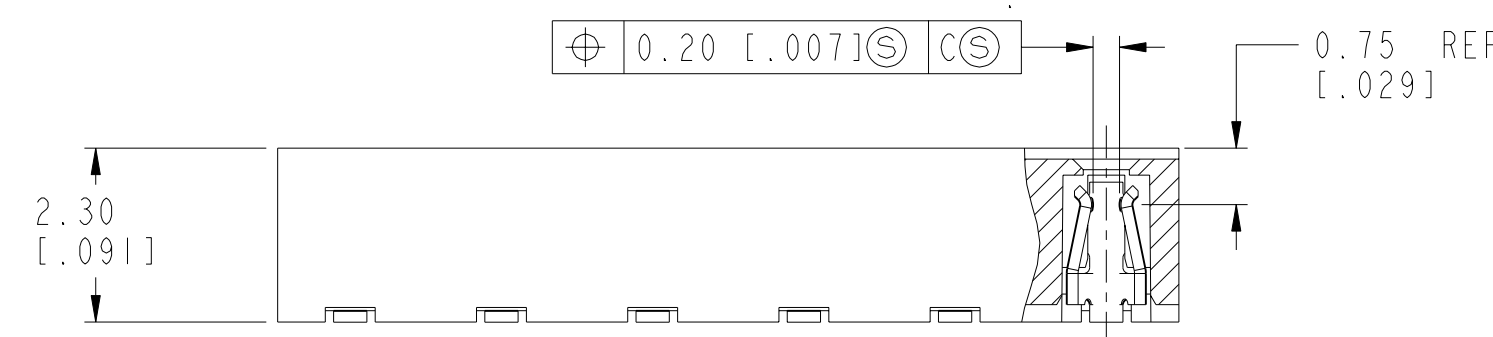

DETAIL A
SCALE 40:1

CONFIDENTIAL

www.fciconnect.com			surface - ✓ ISO 1302	tolerance std ISO 406 ISO 1101	projection MM / INCH
TOLERANCES UNLESS OTHERWISE SPECIFIED					
Dr	JPEH	2002-07-19	ANGULAR	0.X	±0.3
Eng	JPEH	2002-07-19		LINEAR	0.XX
Chr	KH LEE	2009-08-18	0° ±2°	0.XXX	±.051
Appr	JOEY NG	2009-08-18	Product family LPVCC		size A3
rev			date		Scale 10:1
A	S10103	JPEH	2001-07-31		ECN S09-0253
B	S10139	JPEH	2001-10-03		Spec ref -
C	S20092	JPEH	2002-07-19		
D	S05-0007	KBM	2005-01-19		
E	S09-0058	KHL	2009-02-24		
F	S09-0253	NBR	2009-08-18		
title			LOW PROFILE VCC 2.3		Rev. F
dwg no			55508		
catalog no			CUSTOMER		sheet 1 of 2

rev	ecn no	dr	date
A	S10103	JPEH	2001-07-31
B	S10139	JPEH	2001-10-03
C	S20092	JPEH	2002-07-19
D	S05-0007	KBM	2005-01-19
E	S09-0058	KHL	2009-02-24
F	S09-0253	NBR	2009-08-18
-	-	-	-



Copyright FCI.

PRODUCT NO (5) (6)	POSITIONS	DIM. A	DIM. B
55508-X04	2 X 2	2.00 / .079	3.92 / .154
-X06	2 X 3	4.00 / .158	5.92 / .233
-X08	2 X 4	6.00 / .236	7.92 / .312
-X10	2 X 5	8.00 / .315	9.92 / .391
-X12	2 X 6	10.00 / .394	11.92 / .469
-X14	2 X 7	12.00 / .472	13.92 / .548
-X16	2 X 8	14.00 / .551	15.92 / .627
-X18	2 X 9	16.00 / .630	17.92 / .706
-X20	2 X 10	18.00 / .709	19.92 / .784
-X22	2 X 11	20.00 / .787	21.92 / .863
-X24	2 X 12	22.00 / .866	23.92 / .942
-X26	2 X 13	24.00 / .945	25.92 / 1.020
-X28	2 X 14	26.00 / 1.024	27.92 / 1.099
-X30	2 X 15	28.00 / 1.102	29.92 / 1.178
-X32	2 X 16	30.00 / 1.181	31.92 / 1.257
-X34	2 X 17	32.00 / 1.260	33.92 / 1.335
-X36	2 X 18	34.00 / 1.339	35.92 / 1.414
-X38	2 X 19	36.00 / 1.417	37.92 / 1.493
-X40	2 X 20	38.00 / 1.496	39.92 / 1.572
-X42	2 X 21	40.00 / 1.575	41.92 / 1.650
-X44	2 X 22	42.00 / 1.654	43.92 / 1.729
-X46	2 X 23	44.00 / 1.732	45.92 / 1.808
-X48	2 X 24	46.00 / 1.811	47.92 / 1.887
-X50	2 X 25	48.00 / 1.890	49.92 / 1.965

NOTES:

- HOUSING MAT'L : HIGH TEMP PLASTIC.
- TERMINAL MAT'L : PHOSPHOR BRONZE.
- TERMINAL RETENTION 0.5Kg/1.1 Lbs
- 'V' CUT OPTIONAL - MANUFACTURING PROCESS OPTION.
- SOLDER TAILS OF P/N:55508-XXX IS TIN/LEAD PLATED.
- SOLDER TAILS OF P/N:55508-XXXLF IS 100% MATTE TIN PLATED.

7. PRODUCT DESCRIPTION CODE:

XXXXX-XXXLF



8. PACKAGING:

- (a) XXXXX-XXX ---STD PACKAGING IN TUBE.
- (b) XXXXX-XXXTR ---TAPE AND REEL PACKAGING WITH PICK-UP CAP (SEE FIG 1).
- (c) XXXXX-XXXTRN ---TAPE AND REEL PACKAGING WITHOUT PICK-UP CAP.

9. CO-PLANARITY:

- FROM POSITION - X04 THRU -X38 : 0.10 / .004
- X40 THRU -X50 : 0.12 / .005

10. THE HOUSING WILL WITHSTAND EXPOSURE TO 255°C PEAK TEMPERATURE FOR 10 SECONDS IN A CONVECTION, INFRA-RED OR VAPOR PHASE REFLOW OVEN.

(11) THIS PRODUCT MEETS EUROPEAN UNION DIRECTIVES AND OTHER COUNTRY REGULATIONS AS DESCRIBED IN GS-22-008.

△ 12. A △ SYMBOL WILL BE NEXT TO ANY DIMENSION, VIEW OR NOTE WHICH HAS BEEN MODIFIED WITH THE CURRENT DRAWING REVISION.

PLATING OPTIONS OVER CONTACT AREA

- 0 = 0.05µm/2µ"Au
- 1 = 0.76µm/30µ"Au
- 3 = 0.38µm/15µ"Au

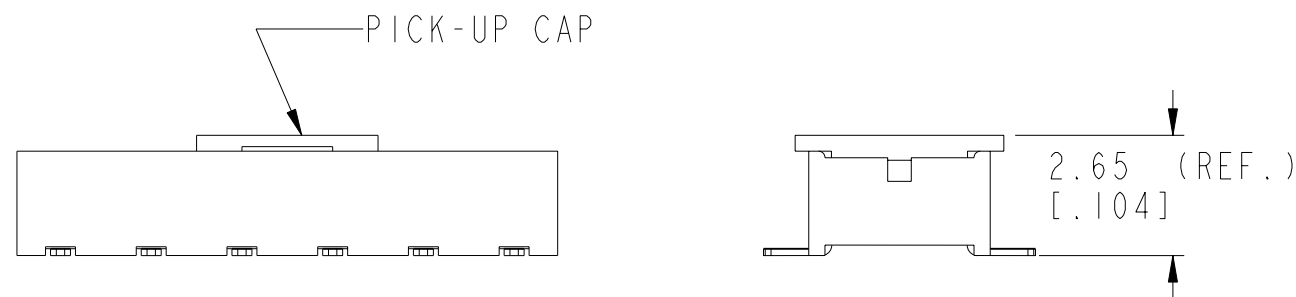

FIG. 1

www.fciconnect.com			surface - ISO 1302	tolerance std ISO 406 ISO 1101	projection MM / INCH
			TOLERANCES UNLESS OTHERWISE SPECIFIED		← →
Dr	JPEH	2002-07-19	ANGULAR	0.X ±0.3	size A3
Eng	JPEH	2002-07-19	LINEAR	0.XX ±.13	Scale 10:1
Chr	KH LEE	2009-08-18	0° ±2°	0.XXX ±.051	ECN S09-0253
Appr	JOEY NG	2009-08-18	Product family	LPVCC	Spec ref -
FCj			LOW PROFILE VCC 2.3		dwg no 55508
			TOP ENTRY SMT ASSY		Rev. F
catalog no			-		CUSTOMER sheet 2 of 2

CONFIDENTIAL