

Tous droits strictement reserves. Reproduction ou communication a des tiers interdite sous quelque forme que ce soit sans autorisation écrite du propriétaire. Propriete de c FCI. Droits de reproduction FCI.

All rights strictly reserved. Reproduction or issue to third parties in any form whatever is not permitted without written authority from the proprietor. Property of FCI. Copyright FCI.

PRODUCT NO. 51952-014-- NOTE 3	POWER																										
	E1	P1	P2	P3	P4	P5	P6	P7	P8	P9	P10	P11	P12	P13	P14	P15	P16	P17	P18	P19	P20	P21	P22	P23	P24	P25	E2
		PC	PC	PC	PC	PC	PC	PC	PC	PC	PC	PC	PC	PC	PC	PC	PC	PC	PC	PC	PC	PC	PC	PC	PC	PC	

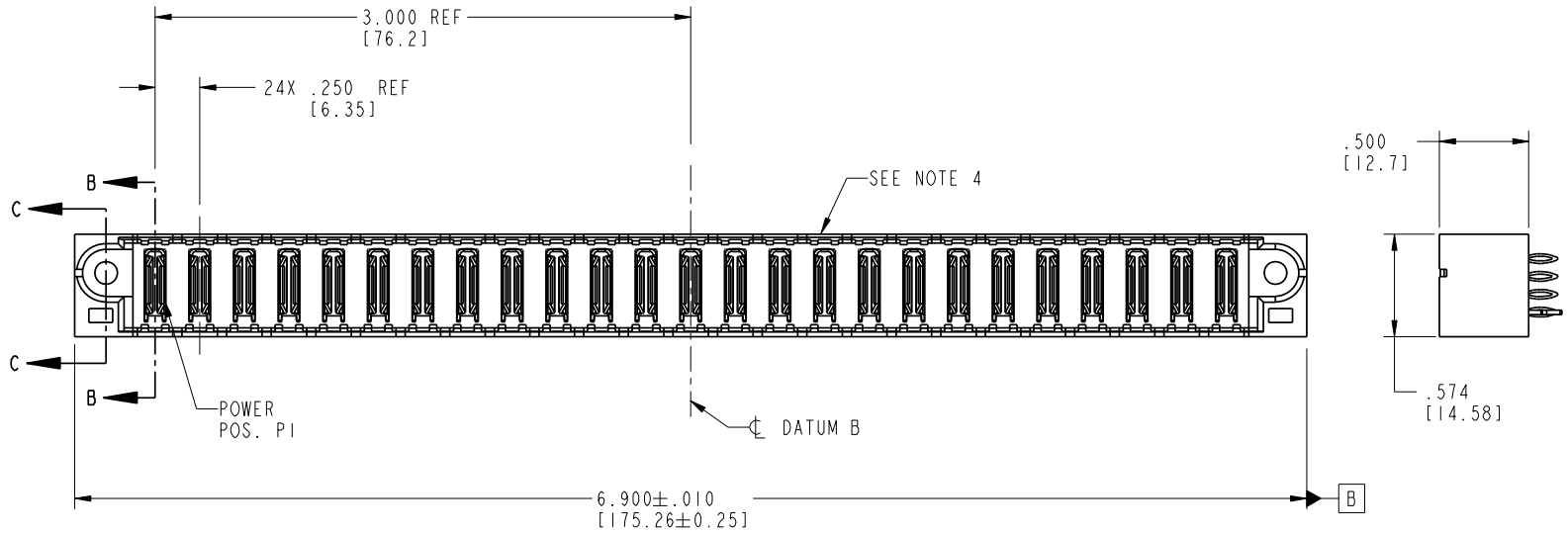

CODE	DIM "M" MATING LENGTH	CONTACT TYPE
PC	N/A [N/A]	POWER
HA	N/A [N/A]	HOLD-DOWN

mat'l code SEE NOTE 2				tolerances unless otherwise specified		CUSTOMER		FCI www.fciconnect.com	
lir	ecn no.	dr	date	linear	projection	COPY			
A	V03-0011	TAB	01/09/03	.XX±.01/0.X±0.3		title 25P VERTICAL PRESS-FIT HEADER			
B	DG05-0478	Ryan	11/18/05	.XXX±.005/0.XX±0.13 .XXX±.002/0.XXX±0.051					
				angles	INCH/MM		product family PwrBlade		code 213
				dr	scale 1:1		size		sheet 1 of 4
				engr			dwg no		
				chr			51952-014		
				appd					
sheet index		revision							
		B	B	B	B				
		1	2	3	4				

cage code 22526

Pro/E

Tous droits strictement reserves. Reproduction ou communication a des tiers interdite sous quelque forme que ce soit sans autorisation écrite du propriétaire. Propriete de c FCI. Droits de reproduction FCI.

All rights strictly reserved. Reproduction or issue to third parties in any form without is not permitted without written authority from the proprietor. Property of FCI. Copyright FCI.

PRODUCT NUMBER
51952-014--
NOTE 3

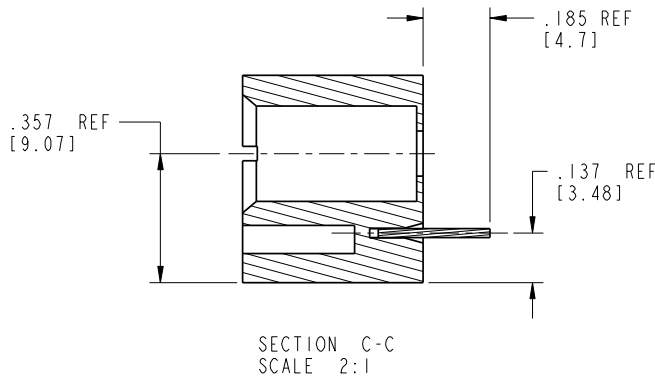
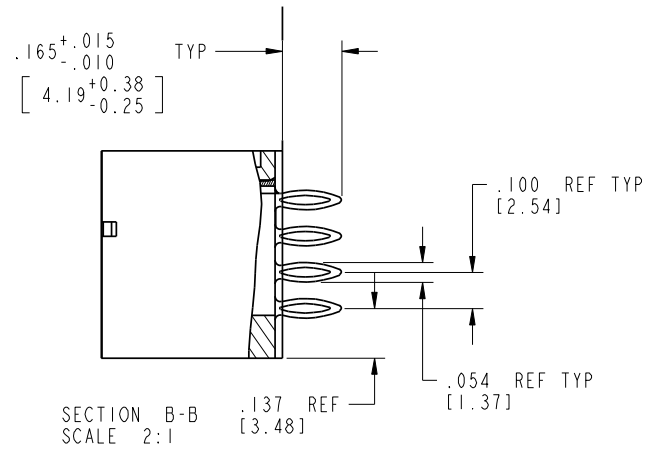

mat'l code SEE NOTE 2				tolerances unless otherwise specified		CUSTOMER		FCI www.fciconnect.com	
lir	ecr no.	dr	date	linear	.XX±.01/0.X±0.3	COPY		title 25P	
B					.XXX±.005/0.XX±0.13	projection		VERTICAL PRESS-FIT HEADER	
				angles	.XXX±.002/0.XXX±0.051	INCH/MM		product family PwrBlade code 213	
				dr	0°±2°	scale 1:1		size A 51952-014 sheet 2 of 4	
				enrg	T. BRUNGARD 01/09/03				
				chr	M. MOSTOLLER 01/09/03				
				appd	M. MOSTOLLER 01/09/03				
sheet index		revision sheet							

cage code 22526

Pro/E

Tous droits strictement reserves. Reproduction ou communication a des tiers interdite sans queleque forme que ce soit sans autorisation ecrite du proprietaire. Propriete de c FCI. Droits de reproduction FCI.

All rights strictly reserved. Reproduction or issue to third parties in any form without is not permitted without written authority from the proprietor. Property of FCI. Copyright FCI.

PRODUCT NUMBER
51952-014--
NOTE 3

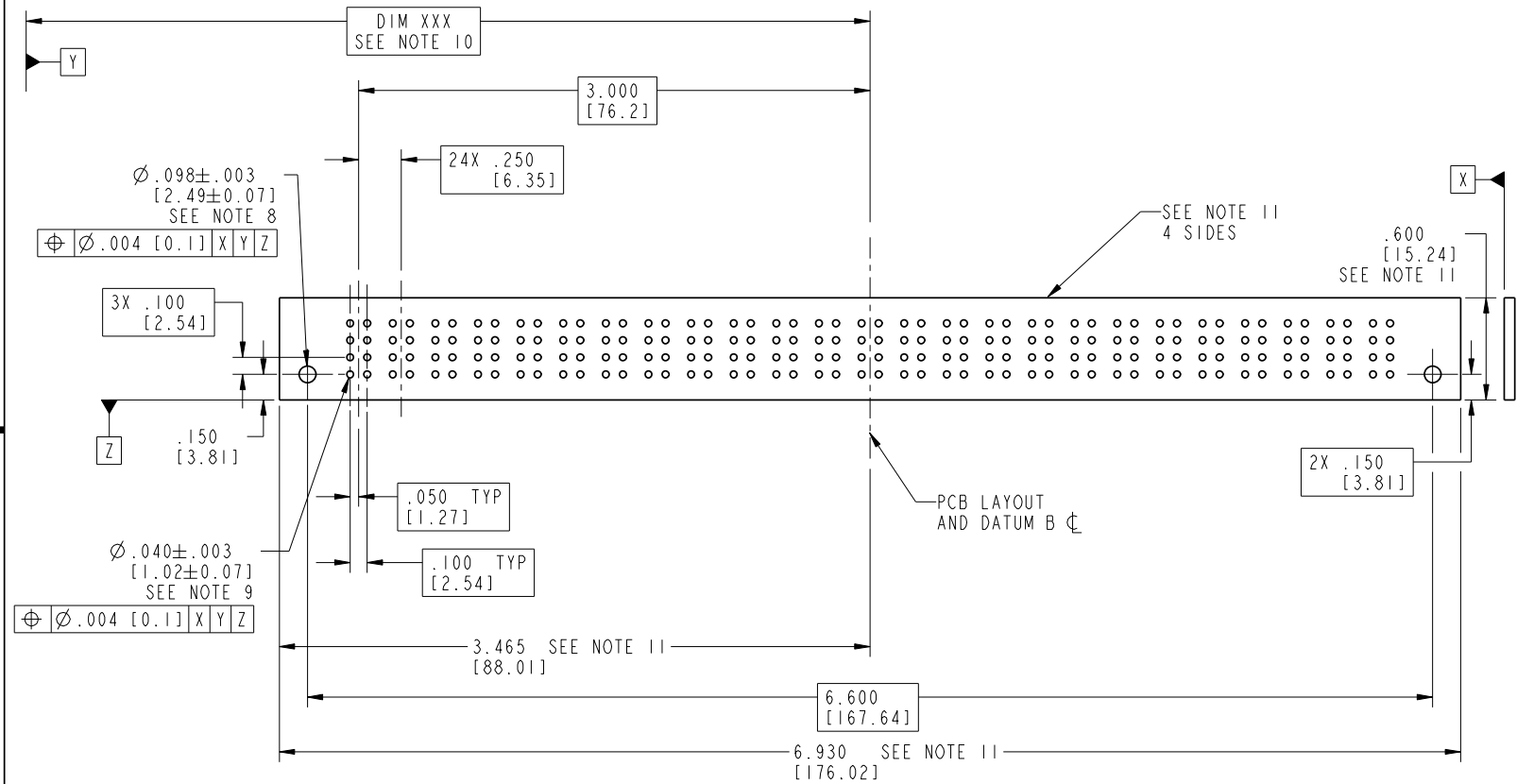

mat'l code		SEE NOTE 2		tolerances unless otherwise specified		CUSTOMER		FCI		www.fciconnect.com	
lir	ecn no.	dr	date	linear	.XX±.01/0.X±0.3	COPY		projection		title	
B					.XXX±.005/0.XX±0.13					25P	
				angles	.XXX±.002/0.XXX±0.051					VERTICAL PRESS-FIT HEADER	
				dr	0°±2°					product family	
				engr	T. BRUNGARD 01/09/03	INCH/MM				PwrBlade	
				chr	M. MOSTOLLER 01/09/03	scale		A		code	
				appd	M. MOSTOLLER 01/09/03	1:1		size		213	
sheet index		revision sheet						51952-014		3 of 4	

cage code 22526

Pro/E

Tous droits strictement réservés. Reproduction ou communication à des tiers interdite sans quelque forme que ce soit sans autorisation écrite du propriétaire. Propriété de c FCI. Droits de reproduction FCI.

A FCI

All rights strictly reserved. Reproduction or issue to third parties in any form without written authority from the proprietor. Property of FCI. Copyright FCI.

B

1 | 2

3 |

4

PRODUCT NUMBER
51952-014_
NOTE 3

NOTES:

1. DIMENSIONS AND TOLERANCES ARE IN ACCORDANCE WITH ASME Y14.5M, 1994 UNLESS OTHERWISE SPECIFIED.

CONNECTOR NOTES:

② HOUSING MATERIAL: UL 94 V-0 GLASS FILLED HIGH-TEMP THERMOPLASTIC

POWER CONTACT MATERIAL: COPPER ALLOY
SIGNAL PIN MATERIAL: COPPER ALLOY

3. PLATING:

51952-014: SIGNAL PIN: 30u"/0.76um Au OVER 50u"/1.27um Ni ON THE CONTACT AREA
AND 100u"/2.54um SnPb OVER 50u"/1.27um Ni ON THE TERMINATION AREA
POWER PIN: 30u"/0.76um Au OVER 50u"/1.27um Ni ON THE CONTACT AREA
AND 100u"/2.54um SnPb OVER 50u"/1.27um Ni ON THE TERMINATION AREA

51952-014LF: SIGNAL PIN: 30u"/0.76um Au OVER 50u"/1.27um Ni ON THE CONTACT AREA
AND 78u"/2.00um Sn OVER 50u"/1.27um Ni ON THE TERMINATION AREA
POWER PIN: 30u"/0.76um Au OVER 50u"/1.27um Ni ON THE CONTACT AREA
AND 78u"/2.00um Sn OVER 50u"/1.27um Ni ON THE TERMINATION AREA

PART NUMBER 51952-014LF MEETS EUROPEAN UNION DIRECTIVE AND OTHER COUNTRY REGULATIONS AS DESCRIBED IN GS-22-008.

THE HOUSING WILL WITHSTAND EXPOSURE TO 260° PEAK TEMPERATURE FOR 10 SECONDS IN A WAVE SOLDER APPLICATION WITH A CIRCUIT BOARD.

④ MANUFACTURER'S NAME, P/N, AND DATE CODE TO APPEAR ON THIS SURFACE.

5. PRODUCT SPECIFICATION GS-12-149.
APPLICATION SPECIFICATION BUS-20-067.

6. PACKAGED IN TRAYS.

PCB NOTES:

7. ALL HOLE DIAMETERS ARE FINISHED HOLE SIZE.

8. MOUNTING HOLES, WHERE APPLICABLE, ARE UNPLATED.

⑨ $\varnothing .0453 \pm .0010$ [1.151 ± 0.025] PREPRESSED THROUGHS PLATED WITH FCI CAM TOOL 430169-XXX.

.0003 [0.008] MIN SnPb OVER .001 [0.03]
TO .003 [0.08] Cu PLATING TO ACHIEVE
 $\varnothing .040 \pm .003$ [1.02 ± .07] HOLE.

⑩ "DIM XXX" TO BE DETERMINED BY THE CUSTOMER.

⑪ CONNECTOR KEEP-OUT ZONE.

12. FOR PRESS FIT APPLICATION,
USE FCI CAM TOOL 430169-XXX.

mat'l code				SEE NOTE 2		tolerances unless otherwise specified		CUSTOMER		A FCI		www.fciconnect.com		
lfr	ecr no.	dr	date	linear	.XX±.01/0.X±0.3	projection	COPY					title		
B				angles	.XXX±.005/0.XX±0.13		25P					VERTICAL PRESS-FIT HEADER		
				dr	.XXX±.002/0.XXX±0.051		INCH/MM					product family		
				enrg	0° ± 2°		scale					PwrBlade		
				chr	T. BRUNGARD 01/09/03		1:1					code		
				appd	M. MOSTOLLER 01/09/03		A					213		
					M. MOSTOLLER 01/09/03		51952-014					sheet		
												4 of 4		
sheet index	revision sheet													

1 | 2

Pro/E

3 |

cage code 22526

4