

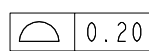

This document is the property of and embodies
 CONFIDENTIAL and PROPRIETARY information of FCI.
 No part of the information shown on this
 document may be used in any way or disclosed
 to others without the written consent of FCI.
 Copyright FCI.

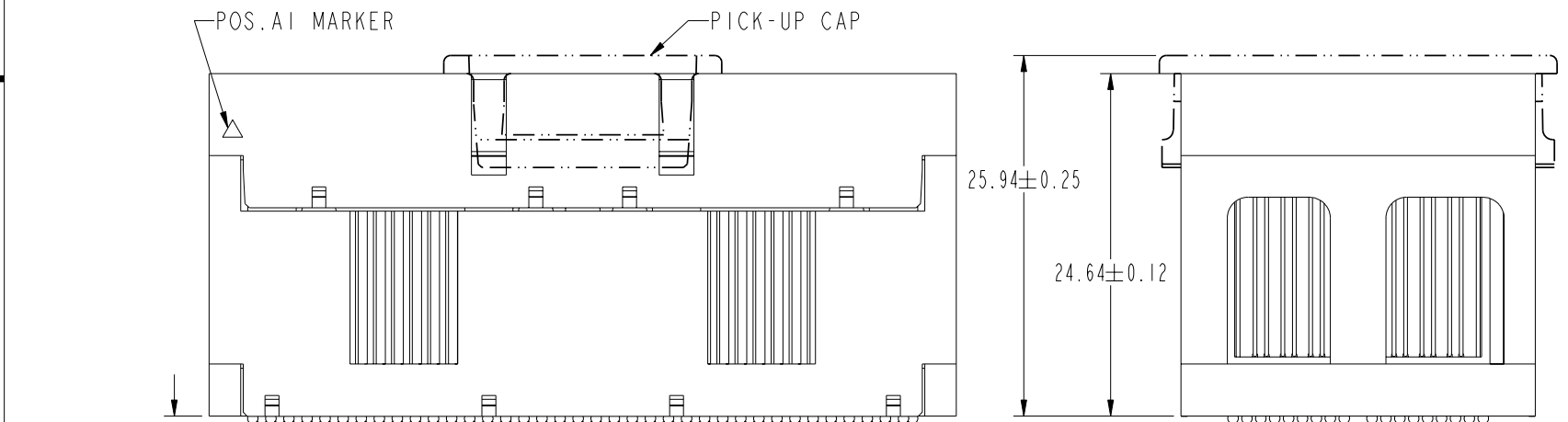
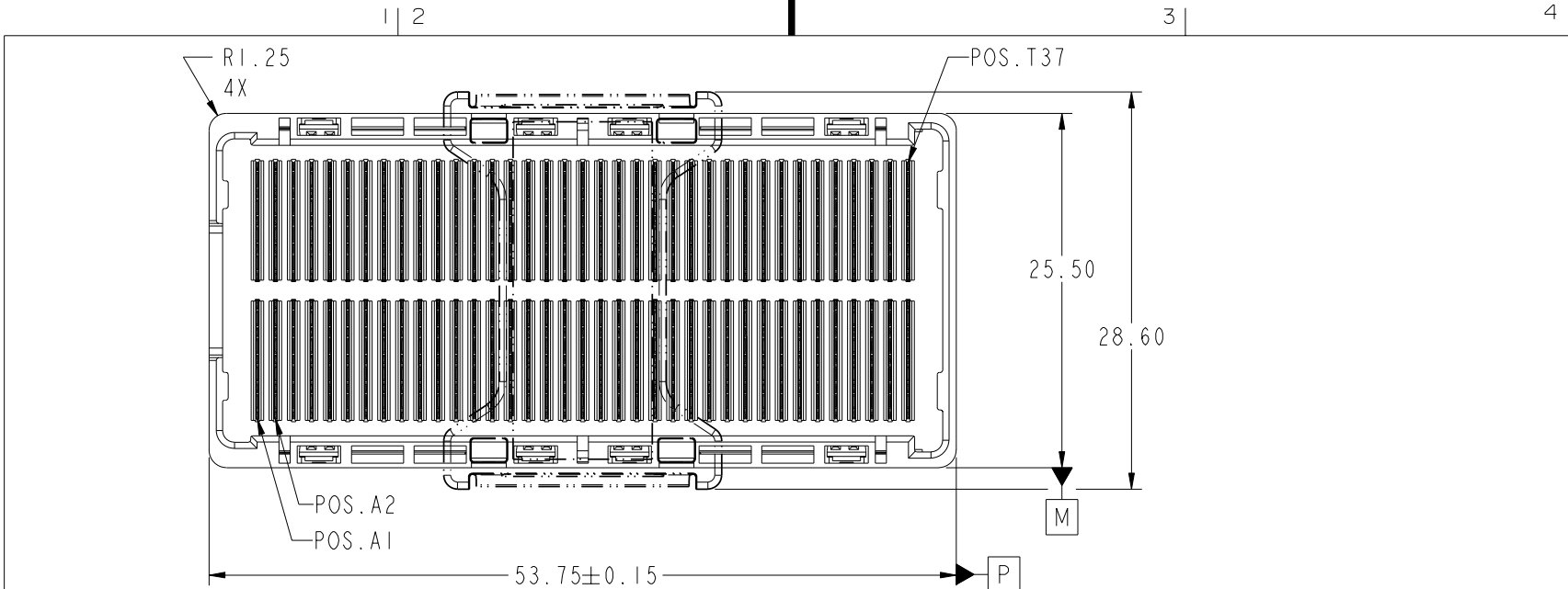

(0.55)

$\varnothing 0.76$ SOLDER BALLS
 $\varnothing 0.30$ P M
 666X
 SEE NOTE 2

mat'l code				SEE NOTE 1			tolerances unless otherwise specified		CUSTOMER		FCI	
ltr	ecn no.	dr	date	linear	0.X ± 0.3		COPY		www.fciconnect.com			
A	V05-0335	TAB	2005-04-25	linear	0.XX ± 0.10		projection		title			
B	V06-0239	LP	2006-03-27	angles	0.XXX ± 0.050				GIG-Array			
C	V06-0558	LP	2006-06-21	dr	0° ± 2°				25mm PLUG ASSY. 296 SIG. POS.			
D	V07-0440	LP	2007-07-09	engr	T. BRUNGARD	2005-04-25	MM		product family		code	
E	V08-0329	SM	2008-11-17	chr	D. HARPER	2005-04-25	1:2		GIG-Array		213	
				appd	D. HARPER	2005-04-25			size		sheet	
								A		10054784		
										1 of 5		
sheet index	revision sheet	E 1	E 2	E 3	E 4	E 5						



title GIG-Array
 25mm PLUG ASSY. 296 SIG. POS.
 product family GIG-Array code 213
 size A dwg no 10054784 sheet 1 of 5

cage code 22526



This document is the property of and embodies CONFIDENTIAL and PROPRIETARY information of FCI. No part of the information shown on this document may be used in any way or disclosed to others without the written consent of FCI. Copyright FCI.

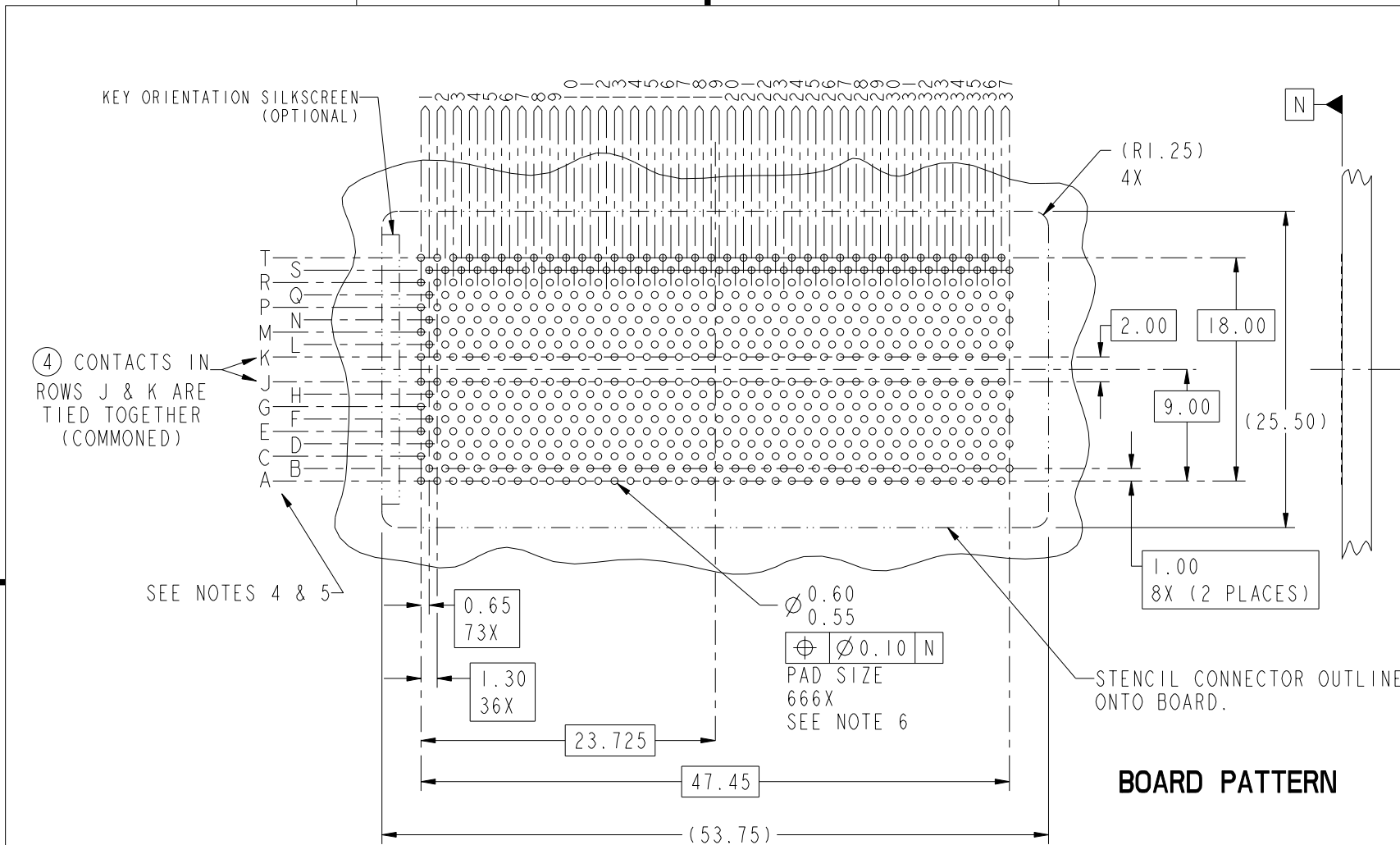

mat'l code				SEE NOTE 1		tolerances unless otherwise specified		CUSTOMER		FCI www.fciconnect.com	
ltr	ecn no.	dr	date	linear	0.X ±0.3		COPY		title		
E	-	-	-		0.XX ±0.10		projection		GIG-Array		
				angles	0.XXX ±0.050				25mm PLUG ASSY. 296 SIG. POS.		
				dr	T. BRUNGARD	2005-04-25	MM		product family		code
				engr	D. HARPER	2005-04-25	← MM →		GIG-Array		213
				chr	D. HARPER	2005-04-25	scale		size		sheet
				appd	D. HARPER	2005-04-25	2:1		dwg no		2
sheet index		revision sheet						A		10054784	

A

B

A

B

1 | 2

3

4

1 | 2

3

4

Pro/E

PDM: Rev:E

STATUS: Released



Printed: Sep_03_2010

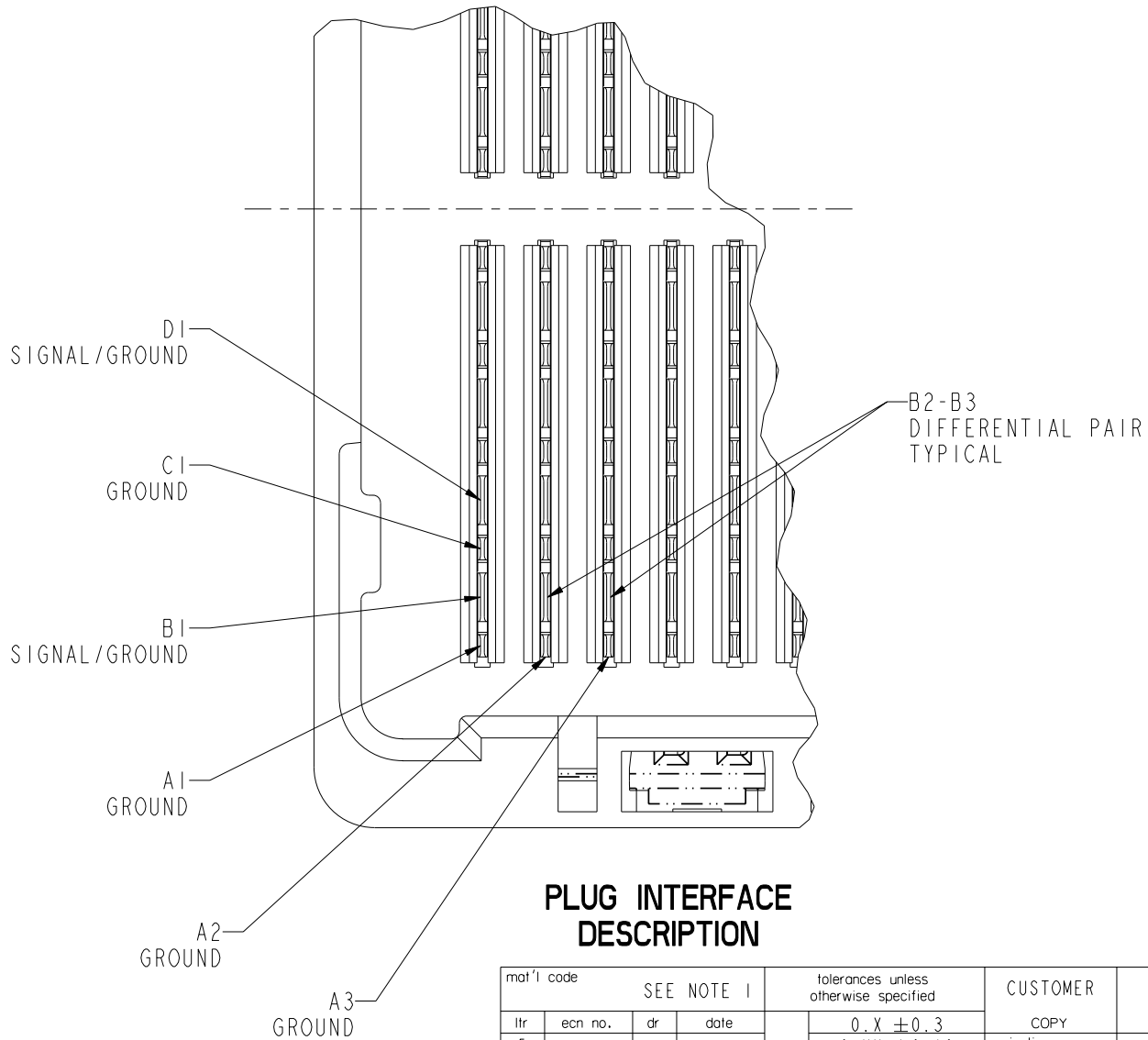

This document is the property of and embodies
 CONFIDENTIAL and PROPRIETARY information of FCI.
 No part of the information shown on this
 document may be used in any way or disclosed
 to others without the written consent of FCI.
 Copyright FCI.

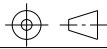

PLUG INTERFACE DESCRIPTION

mat'l code				SEE NOTE 1		tolerances unless otherwise specified		CUSTOMER		 www.fciconnect.com		
ltr	ecn no.	dr	date	linear	0.X ±0.3		COPY		title GIG-Array 25mm PLUG ASSY. 296 SIG. POS.			
E	-	-	-		0.XX ±0.10		projection					
				angles	0.XXX ±0.050				product family GIG-Array code			
					0° ±2°				size		213	
				dr	T. BRUNGARD	2005-04-25	MM		size		sheet	
				engr	D. HARPER	2005-04-25	7:1		A		3	
				chr	D. HARPER	2005-04-25			10054784			
				appd	D. HARPER	2005-04-25						
sheet index		revision sheet										

A

A

B

B

PRODUCT NUMBER	SOLDER BALL
10054784-001	SnPb
10054784-001LF	SnAgCu LEADFREE SEE NOTE 7 8

FLAT AREA
FOR
PICK-UP CAP

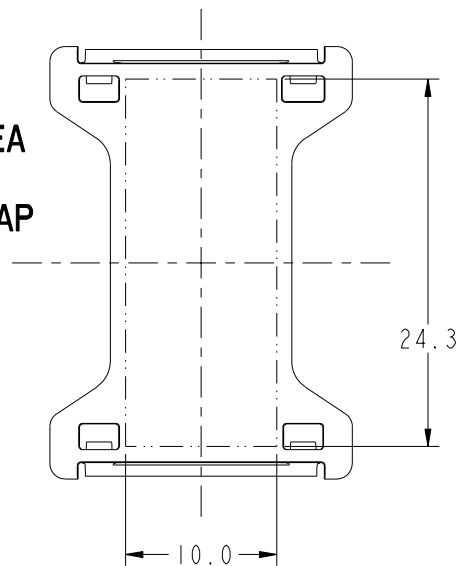

NOTES:

- ① MAT'L:
HOUSING: LCP
CONTACT: COPPER ALLOY
PLATING (CONTACT): Au OVER Ni.
UL RATING: 94 V-0
SOLDER BALL: (SEE TABLE) EUTECTIC
SnPb OR LEADFREE 95.5 Sn/4Ag/0.5Cu
- ② SOLDER BALLS WILL NOT BE PERFECT SPHERICAL SHAPE DUE TO REFLOW ATTACHMENT.
- ③ MATED HEIGHT EFFECTED BY CUSTOMERS' PCB PAD SIZE, PLATING, SOLDER REFLOW PROFILE & SOLDER PASTE.
- ④ CONTACTS IN ROWS A,C,E,G,J,K,M,P,R AND T ARE SINGLE BEAM CONTACTS USED AS GROUND PINS.
(NOTE: CONTACTS IN ROWS J & K ARE TIED TOGETHER [COMMONED])

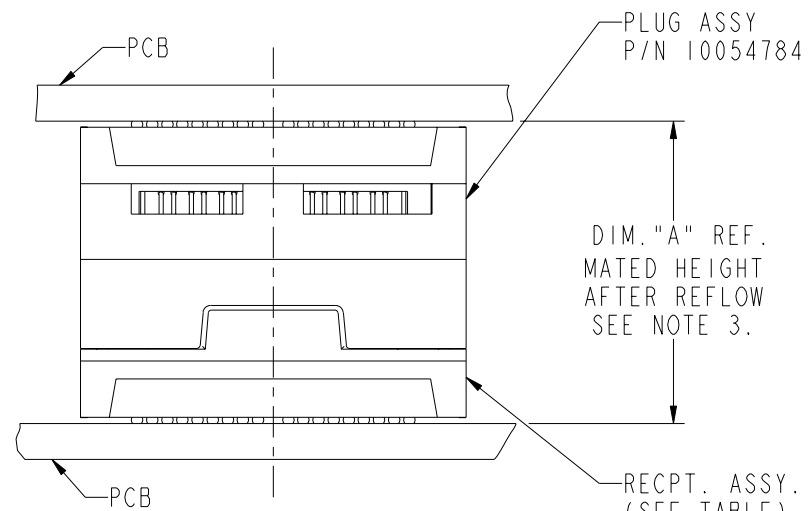

END VIEW OF MATED CONNECTORS

DIM. "A"	RECPT. ASSY. P/N
30	55701
35	10032376
40	55733

NOT TOOLED



This document is the property of and embodies CONFIDENTIAL and PROPRIETARY information of FCI. No part of the information shown on this document may be used in any way or disclosed to others without the written consent of FCI. Copyright FCI.

mat'l code				SEE NOTE 1	tolerances unless otherwise specified	CUSTOMER	FCI www.fciconnect.com	
ltr	ecn no.	dr	date	linear	0.X ±0.3	COPY	title	
E	-	-	-	projection	0.XX ±0.10	MM	GIG-Array	
				angles	0.XXX ±0.050	1:2	25mm PLUG ASSY. 296 SIG. POS.	
				dr	0° ±2°		product family	GIG-Array
				enrg	T. BRUNGARD 2005-04-25		size	dwg no
				chr	D. HARPER 2005-04-25		A	10054784
				appd	D. HARPER 2005-04-25		code	213
sheet index	revision sheet						sheet	4

Pro/E

PDM: Rev:E

STATUS: Released

Printed: Sep_03_2010

- ⑤. CONTACTS IN ROWS B,D,F,H,L,N,Q AND S ARE DUAL BEAM CONTACTS, TYPICALLY USED AS SIGNAL PINS.
- ⑥. SPECIFIED POSITIONAL TOLERANCE DEFINES PAD TO PAD LOCATION WITHIN LAND PATTERN. POSITIONAL TOLERANCE OF LAND PATTERN TO FUDICIAL MARKS OR PCB DATUMS SHALL BE DEFINED BY CUSTOMER. FOR RECOMMENDED PRODUCT APPLICATION AND PCB DESIGN DETAILS, SEE DOC. NO. GS-20-016.
- ⑦. FOR PROPER APPLICATION FOLLOW FCI APPLICATION SPECIFICATION GS-20-033 LEADFREE SOLDER BALLS WILL NOT SOLDER PROPERLY IN A LEADED SOLDER PROCESS DUE TO A HIGHER REFLOW TEMPERATURE, LEADFREE PRODUCT IS THEREFORE NOT BACKWARDS COMPATIBLE WITH LEADED OR SOME SOLDERING APPLICATIONS. REFERENCE FCI APPLICATION SPECIFICATION.
- ⑧. THIS PRODUCT MEETS THE EUROPEAN UNION DIRECTIVES AND OTHER COUNTRY REGULATIONS AS DESCRIBED IN GS-22-008 PRODUCT MEETING THIS DIRECTIVE IS IDENTIFIED IN THE LOT CODE NUMBER MARKED ON EACH PART BY HAVING AN "X" IN THE SEVENTH CHARACTER POSITION.

A



A



This document is the property of and embodies CONFIDENTIAL and PROPRIETARY information of FCI. No part of the information shown on this document may be used in any way or disclosed to others without the written consent of FCI. Copyright FCI.

B

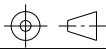
B

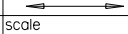
mat'l code				0		tolerances unless otherwise specified		CUSTOMER		 www.fciconnect.com	
ltr	ecn no.	dr	date	linear	0.X ±0.3		COPY		projection	title	
E					0.XX ±0.10					GIG-Array 25mm PLUG ASSY. 296 SIG. POS.	
				angles	0° ±2°				product family		code
				dr	T. BRUNGARD	2005-04-25			GIG-Array		213
				engr	D. HARPER	2005-04-25	scale 1:2		size	dwg no	sheet
				chr	D. HARPER	2005-04-25	A		10054784		5
				appd	D. HARPER	2005-04-25					
sheet index	revision sheet										